



EstesRockets.com

SATURN 1B SA-206

7251



MODEL ROCKET INSTRUCTIONS

KEEP FOR FUTURE REFERENCE

IMPORTANT: Please record date found on decal and keep for future reference. _____

READ ALL INSTRUCTIONS. Make sure you have all parts and supplies. Test fit all parts before applying glue.

The advent of the Space Age of the 1950s and 1960s along with President Kennedy's ambitious goal of putting man on the moon witnessed NASA's development of the line of powerful Saturn rockets. Before the mighty Saturn V launched Apollo 11 to the moon, the Saturn 1B, a workhorse rocket to be sure, was utilized in numerous test flights. In 1966, the first Saturn 1B lifted off from NASA's Kennedy Space Center. Designed and developed by NASA's Marshall Space Flight Center (MSFC) in Huntsville, Alabama, the AS-201 mission was an uncrewed suborbital flight to test the Saturn 1B and the Apollo Command and Service Modules (CSMs). A total of 14 Saturn 1Bs were constructed: four were launched without crews,

and another five were flown with astronauts aboard! After the completion of the Apollo program, the Saturn 1B launched three missions to the Skylab Space Station in 1973. And in 1975, the Saturn 1B was again used for the Apollo-Soyuz Test Project. From – **NASA.gov**

This Estes scale model is of the SA-206, the first Saturn 1B to launch a crewed command service module (CSM) to Skylab on May 25, 1973.

Enjoy building your Saturn 1B and all the dreams it may inspire!

SUPPLIES:

#220, #320, #400 AND #600 SANDPAPER
PENCIL
TWEEZERS
HOBBY KNIFE AND SEVERAL SHARP BLADES
YELLOW GLUE
TUBE-TYPE PLASTIC CEMENT
LIQUID PLASTIC CEMENT
PERMANENT SPRAY ADHESIVE (NOT ARTIST'S OR REPOSITIONABLE)

CA
CA ACCELERATOR
SANDING SEALER (OR SANDABLE AUTO PRIMER)
PUTTY FOR PLASTIC MODELS
MASKING TAPE
SMALL PAINT BRUSH
FLAT BLACK PAINT
FLAT WHITE PAINT
SILVER PAINT

Do not use lacquer based paints! They can melt the surface of the plastic parts.

Please be extremely careful using cyanoacrylate adhesive (CA). Avoid getting in your eyes or on your skin. Safety glasses are recommended. Use adhesives and paint only in areas with adequate ventilation. Read all instructions.

Before beginning to build with vac-formed plastic parts, read the following carefully.

Cutting Vac-Formed Parts

Cutting vac-formed plastic parts requires patience. Applying light pressure, make repeated passes with the blade to cut through the plastic. Be sure to keep the blade in the same cut line each time; too much pressure will cause the blade to move and not cut cleanly.

Sanding and Trimming Vac-Formed Parts

Once the part is free of excess plastic, sand the edges to remove any flash and to provide a smooth, flat bonding surface. Secure a sheet of #220 or #320 grit sandpaper to a flat surface. (You may want to use wet-or-dry sandpaper with a little water to avoid clogging or loading the sandpaper with plastic dust.) Move each part in a circle against the sandpaper with pressure evenly distributed to avoid uneven sanding. Applying too much pressure can cause uneven edges. When working with thin edges, be careful not to remove too much plastic or generate too much heat that may warp and destroy the part.

NOTE: Double sided tape may be used to hold small parts. Use a file to remove excess plastic on hard to hold small parts.

Adhesives for Vac-Formed Parts

Because vac-formed parts are thinner than injection molded parts, different adhesives should be used. Two basic types give good results and you should have both on hand when building this model.

First is liquid plastic cement. Our preferred brands are Plastic Weld Cement® (Plastruct®), Testor's Plastic Cement #3502®, Tenax 7R®, and Testor's® or Tamiya® glue pens. Liquid cements work on styrene by dissolving the plastic and creating a chemically welded bond. As a result, a little bit goes a long way! Liquid cements are usually applied with an artist's brush. The trick to using plastic cement is to take advantage of the liquid flowing out from the brush by allowing

cement to bleed into close fitting parts and then squeezing the parts together to bond. Work on a small area at one time as plastic cement sets quickly.

The second adhesive to have on hand is a super glue or cyanoacrylate for plastics. We recommend Plasti-Zap®. You'll also want to use CA accelerators for plastics for these, but use a toothpick or a pipette to apply accelerator one drop at a time. When sprayed from their normal applicators, most regular CA accelerators will soften and stain plastic surfaces.

Filling the Seams

This is a necessary step in constructing vac-formed models. Because these models have seams, they need to be filled and smoothed. The putties we recommend are 3M Accyl-Blue® (Usually found at auto body supply shops - one tube will last a long time.) and Squadron® Green or White Putty (usually found in hobby shops.)

When working with putty or filler use as little as possible. Excess putty in a seam creates extra work in sanding it away, as well as the possibility of a "sinkhole" (where the putty collapses the skin of the plastic and eats it away.) Use masking tape along seams to minimize excess putty from adhering to the work area. Use multiple layers when building up low areas, rather than one thick layer of putty. Doing so will reduce shrinkage, cracking, and the risk of sinkholes. Let the putty dry overnight before attempting to sand it away. Wet-or-dry sandpaper, used wet, works best. Start with #220 grit and work your way through #320 to #400. Then polish the area with #600.

The marks ESTES®, the Estes® rocket logo, and Porta-Pad® are marks of Estes Industries, LLC registered in the U.S. and other countries. *All other product names and marks are the property of their respective owners.

PARTS

030019
Saturn 1B Templates
(not shown)

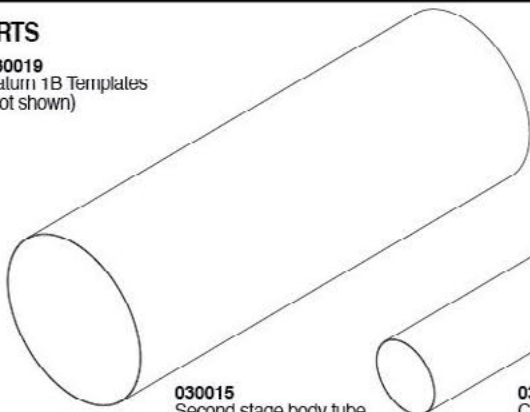

030015
Second stage body tube

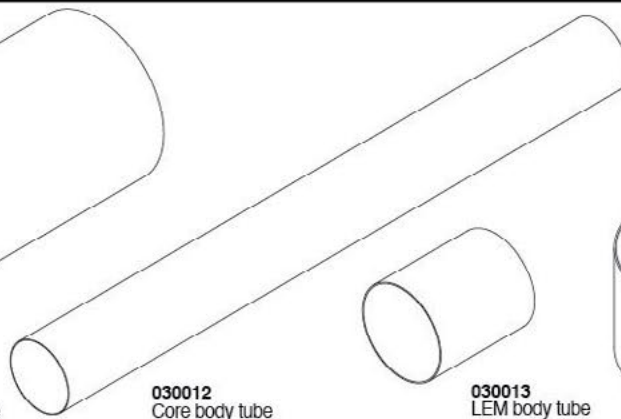

030012
Core body tube



030013
LEM body tube

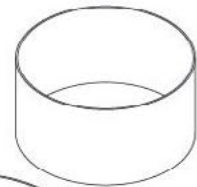

030014
Nozzle spacer tube

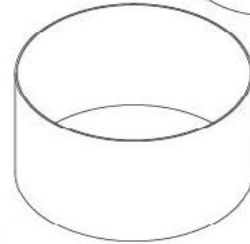

030016
aft body tube

030011
Fuel body tubes
X8

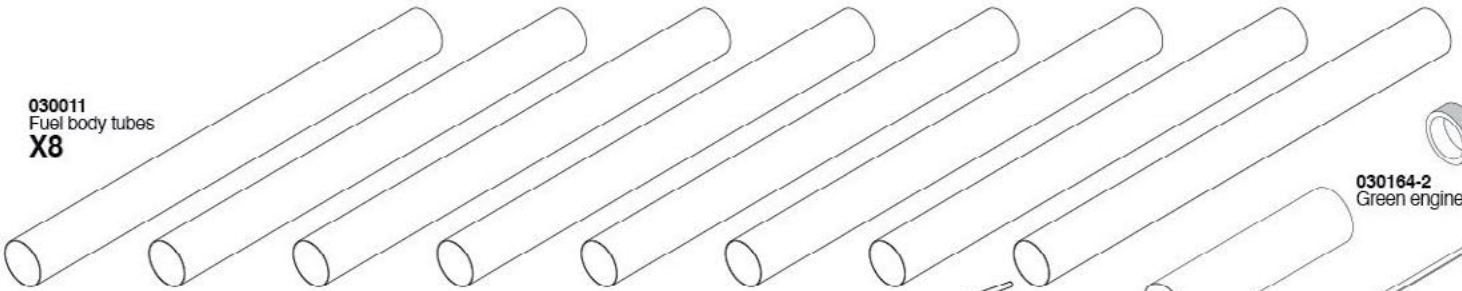

030164-2
Green engine block



073149
Upper body wrap

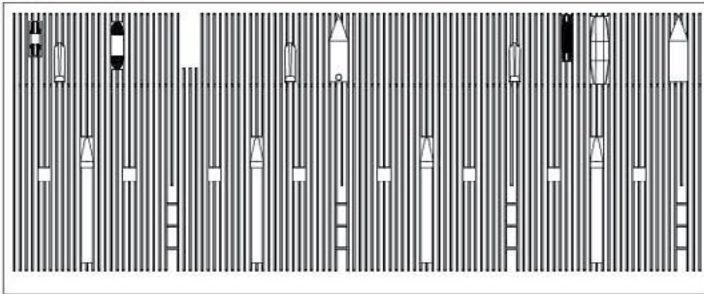

073150
interstage wrap

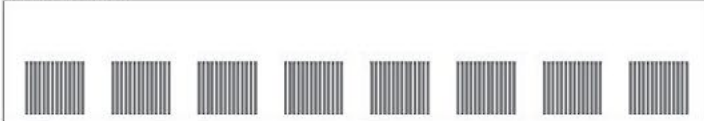

073151
Lower body wrap



068132
Waterslide decal sheet

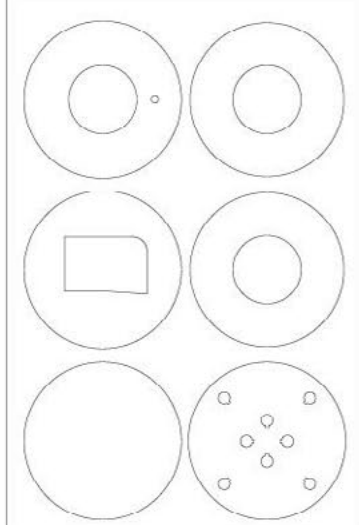

090052-7251
Laser cut card stock

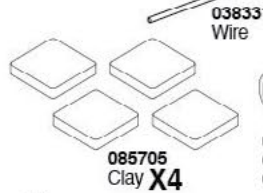

038331
Wire

085705
Clay **X4**

030360
Engine mount tube



035005
Orange E to D engine spacer tube



038265
Snap swivel

035022
E Engine hook



030009
Green centering rings

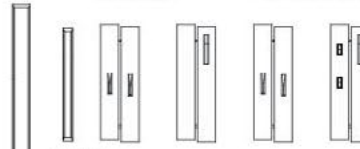

073153
Tunnels and Antenna



073155
Outer engines **X4**



073154
Inner engines **X4**



038165
Launch lugs

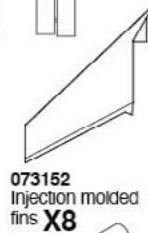

073152
Injection molded fins **X8**

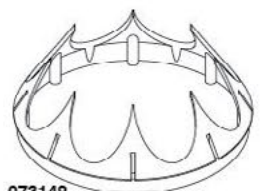

073148
Tank shroud

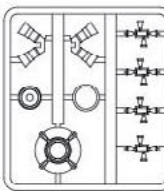

033201
Plastic parts set



030442
Escape motor body

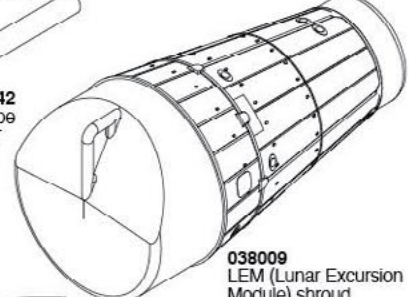

038009
LEM (Lunar Excursion Module) shroud

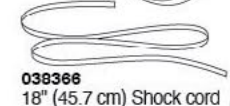

038366
18" (45.7 cm) Shock cord



038380
42" (107 cm) Shock cord



038236
Shroud line

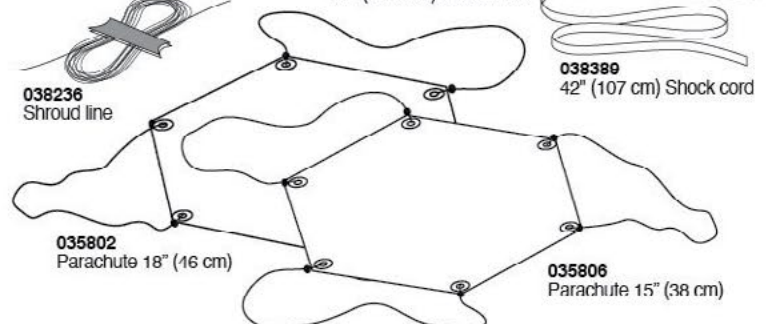

035802
Parachute 18" (46 cm)

035806
Parachute 15" (38 cm)

ASSEMBLE ENGINE MOUNT

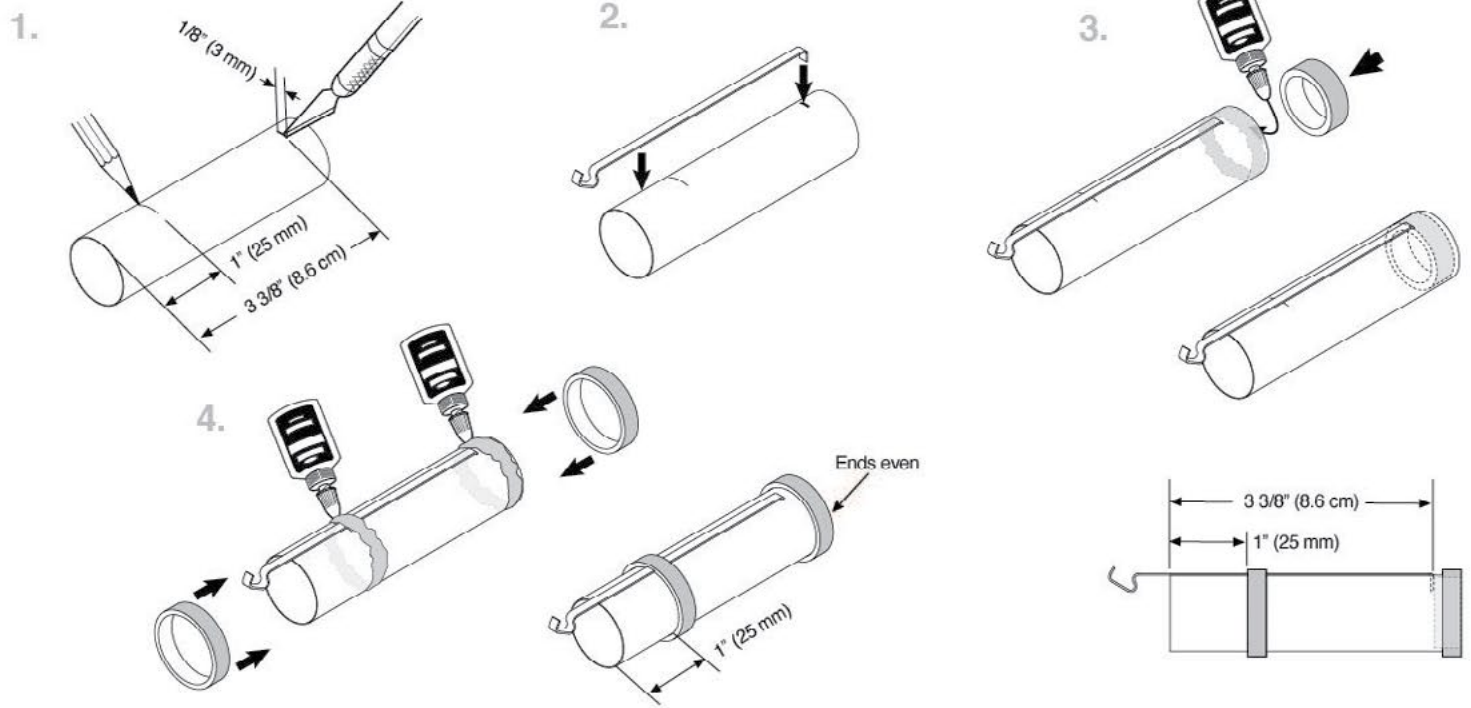

ASSEMBLE AFT BODY SECTION

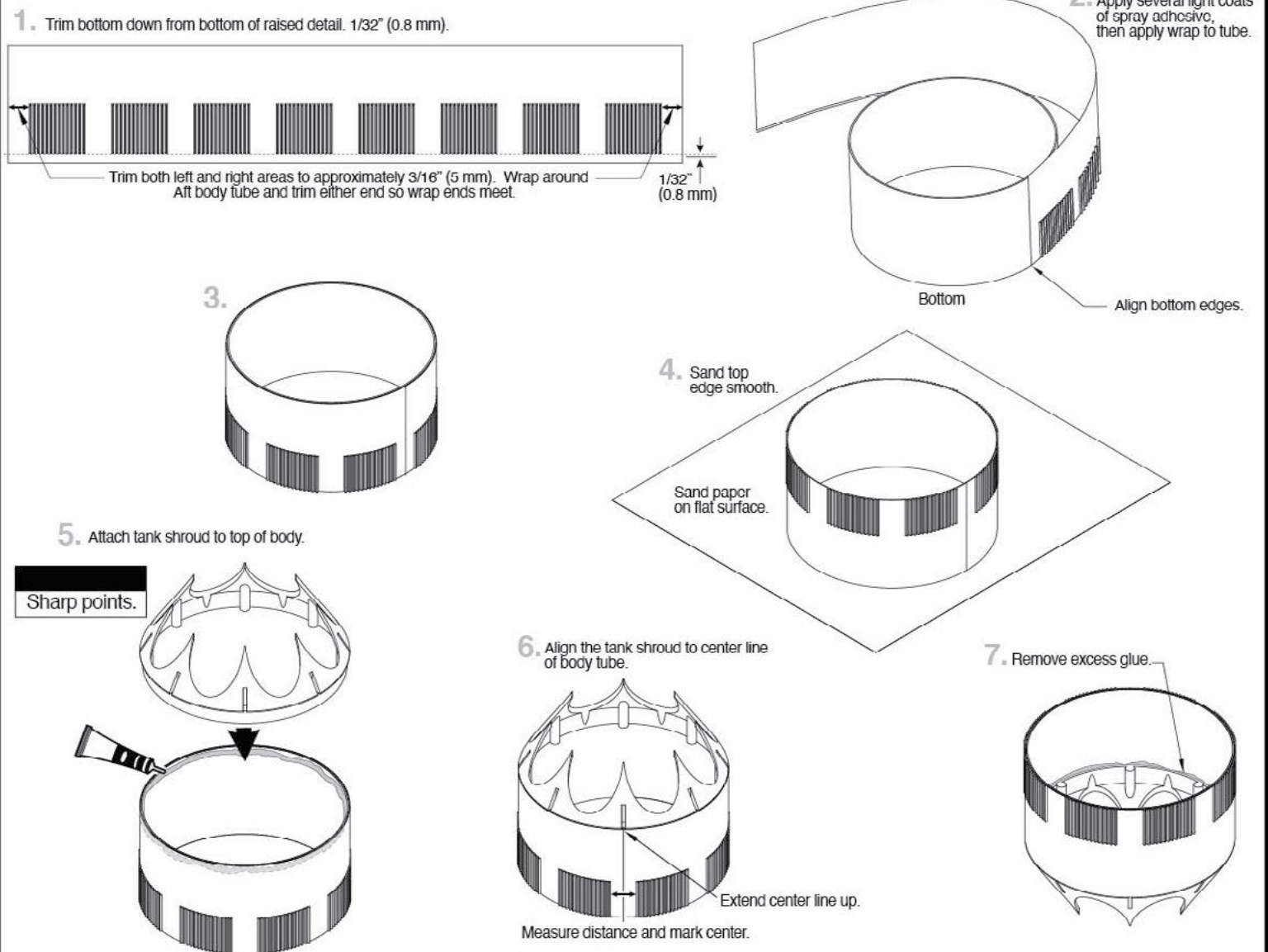

ATTACH FINS

1. Remove this laser cut ring and remove fin alignment jig from ring.

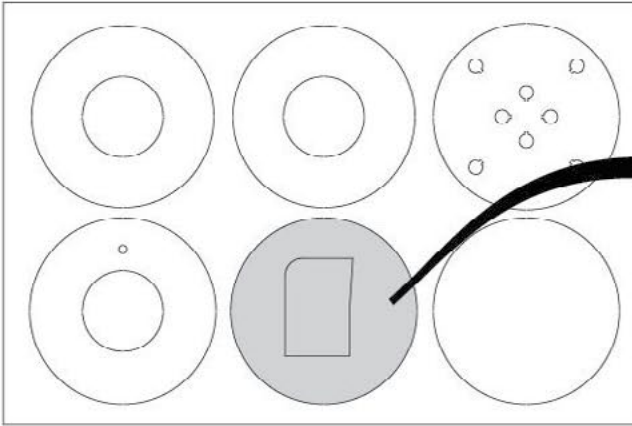

2. Remove fin alignment jig from ring.

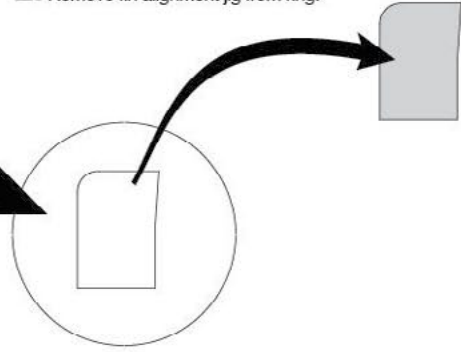

3. Apply glue to top of paper template found on Saturn 1B templates page.

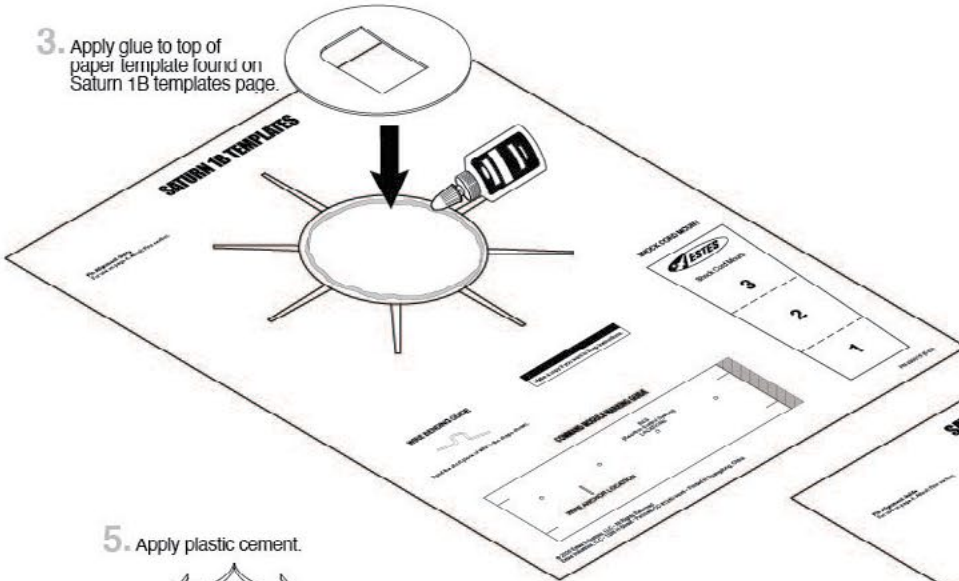

4. Center laser cut ring over printed template.

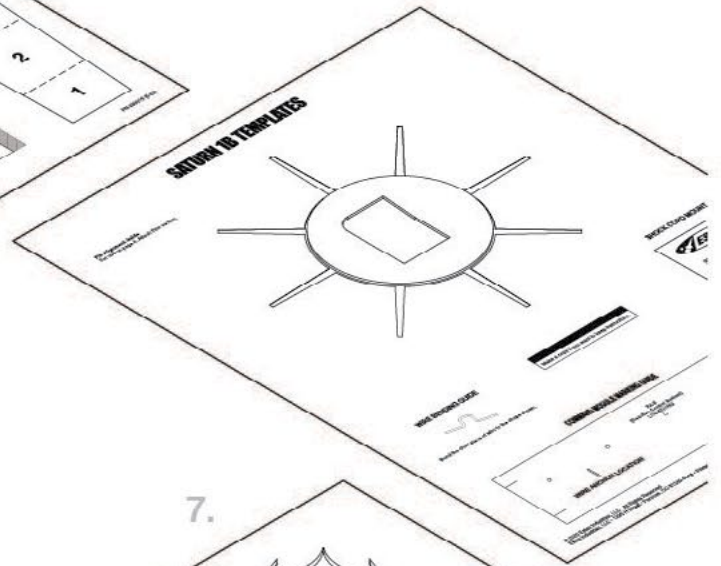

5. Apply plastic cement.

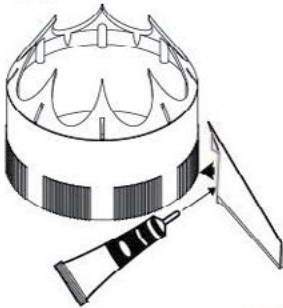

6. Use jig to align fins until dry.

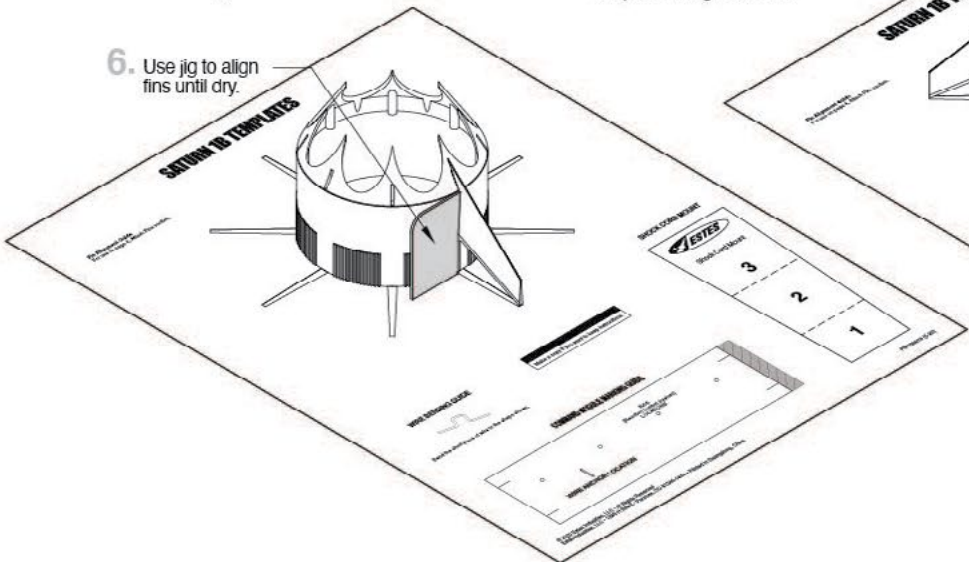

Place assembly over paper template to align all 8 fins.

7.

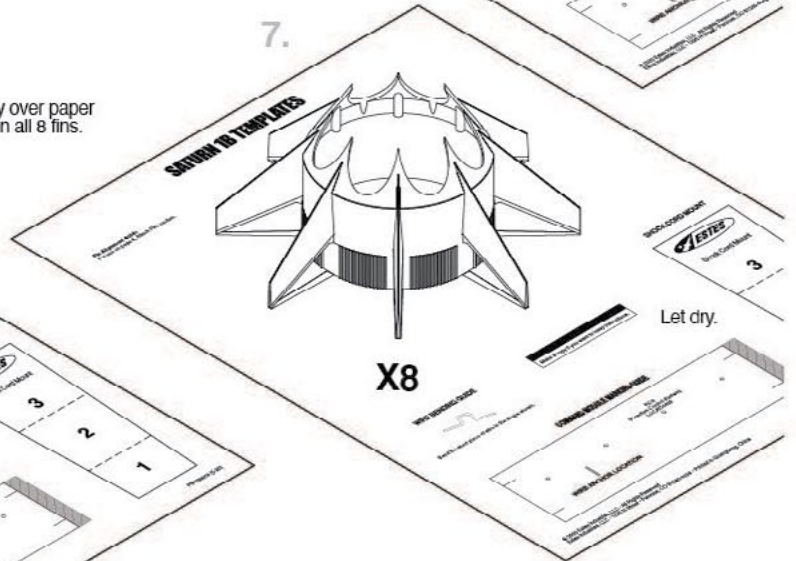

APPLY UPPER BODY WRAPS

1. Trim top & bottom away from edge of raised detail 1/32" (0.8 mm).

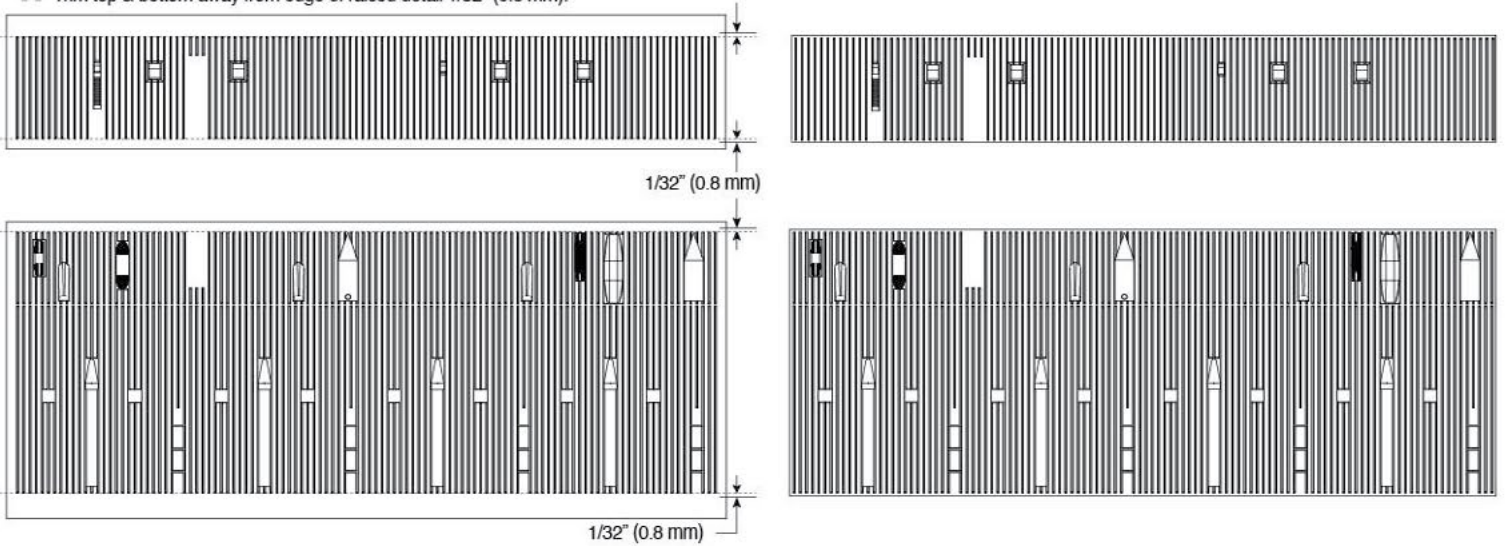

2. Extend pencil line entire length of body tube.

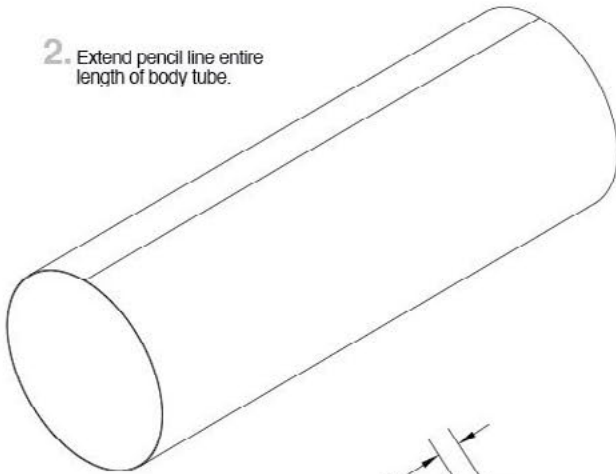

3. Apply several light coats of spray adhesive, then apply wrap to tube.

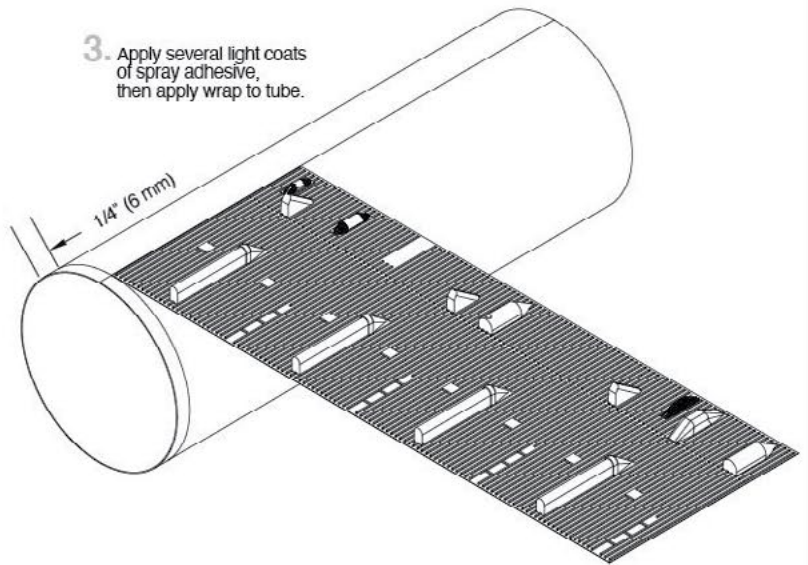

4. Apply several light coats of spray adhesive, then apply wrap to tube.

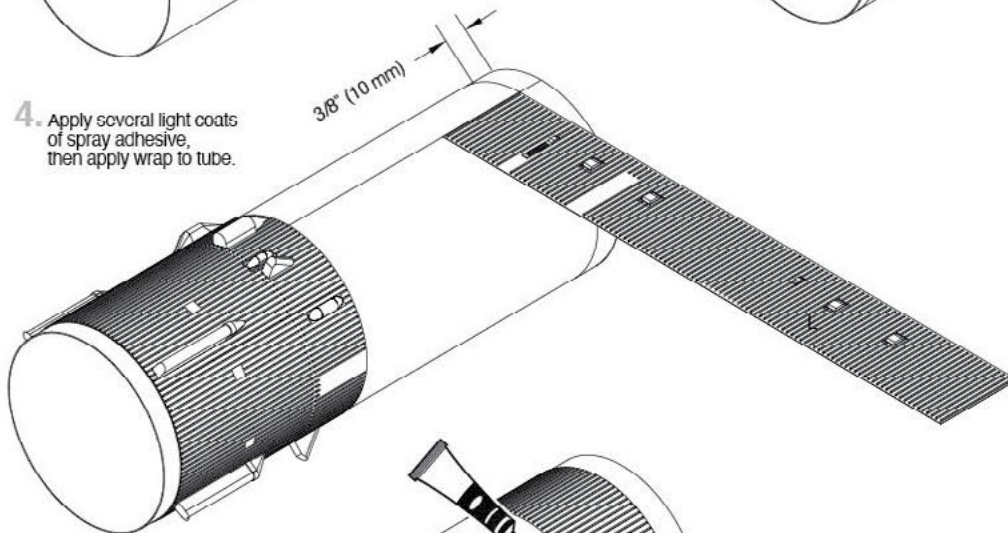

5. Attach tunnels with plastic cement.

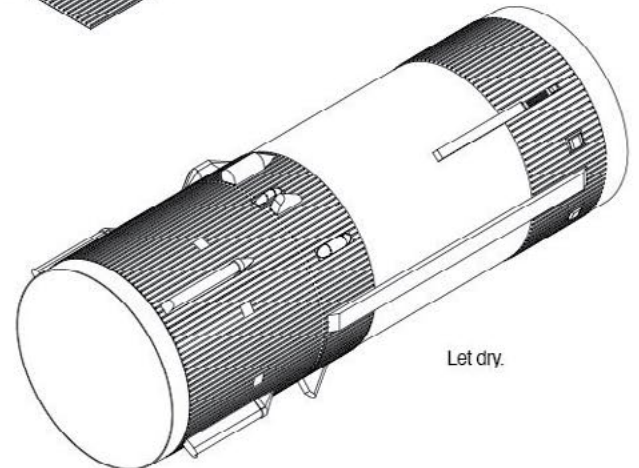
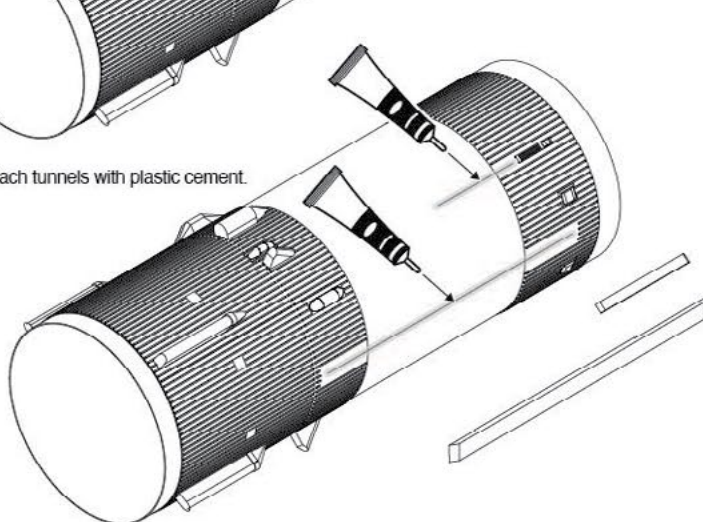

ASSEMBLE FUEL BODY TUBES

1. Attach the core body tube to the laser cut centering ring using yellow glue.

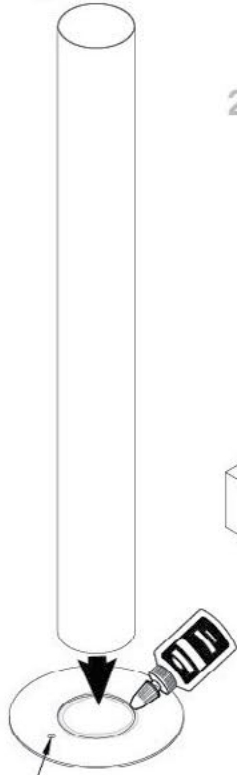

2. Allow to dry on flat surface.

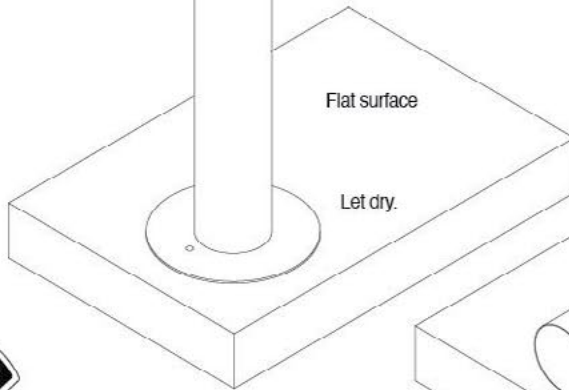

3. Lay core body tube on flat surface with laser cut centering ring hanging off the edge as indicated. Apply glue along entire length of fuel body tube and roll tube onto core tube.

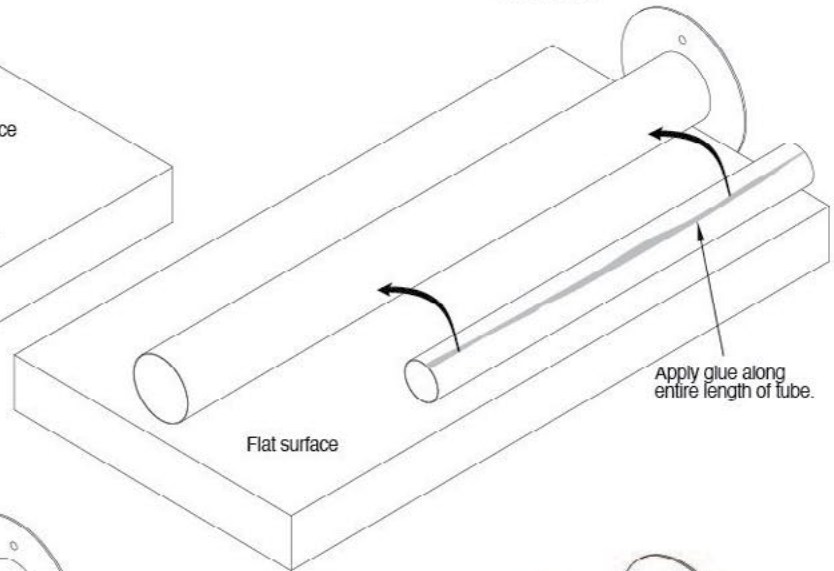
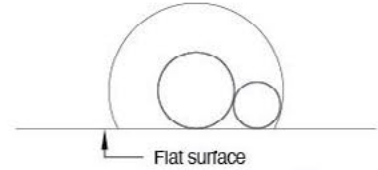

4. Let dry.

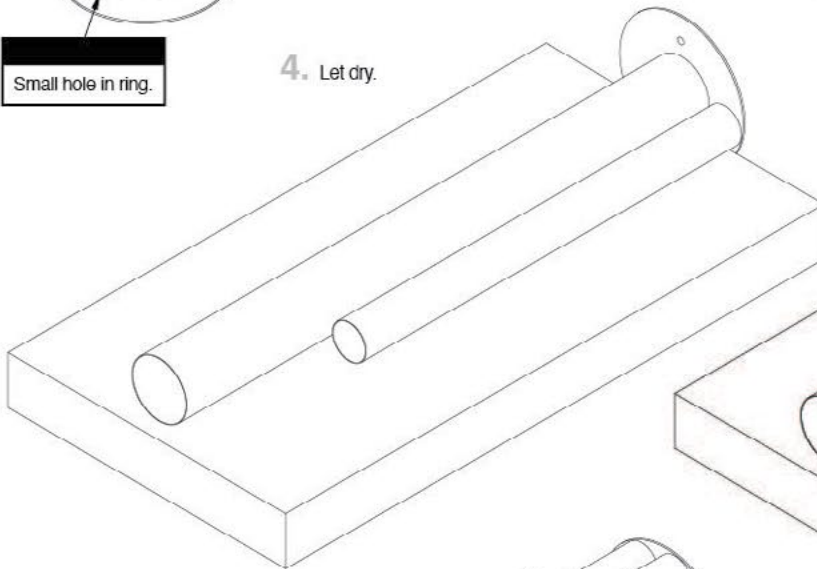

5. Place a second fuel body tube in place using the same gluing application. Let dry.

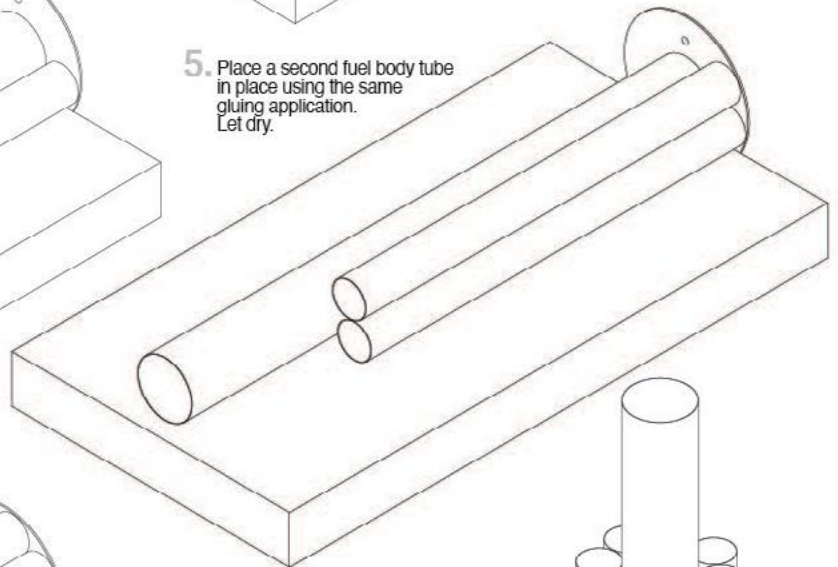

6. Add the next three tubes applying glue as before and allow each to dry.

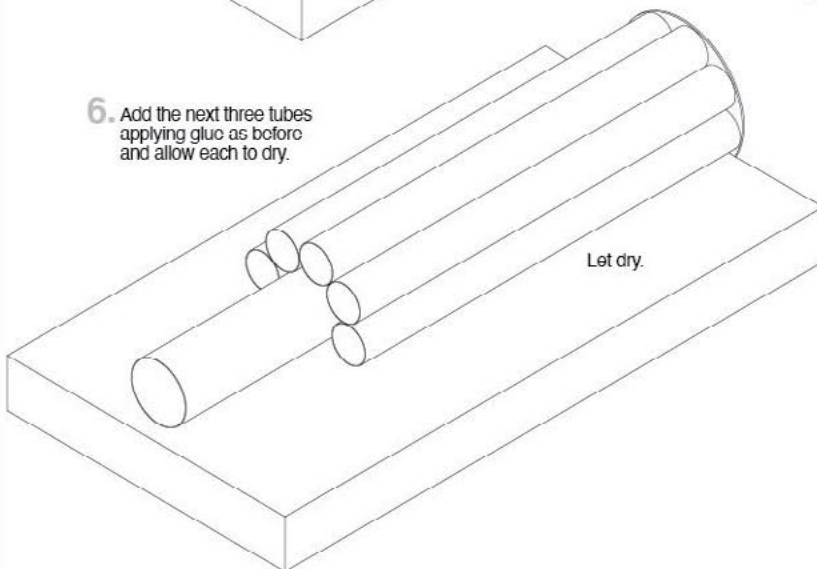

7. Once dry remove from flat surface and add remaining fuel body tubes

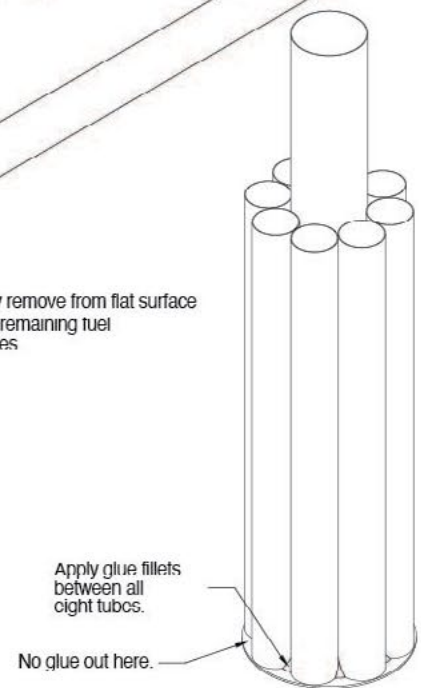

INSTALL ENGINE MOUNT

1. Cut slot in core tube between any two of the outer eight fuel body tubes.

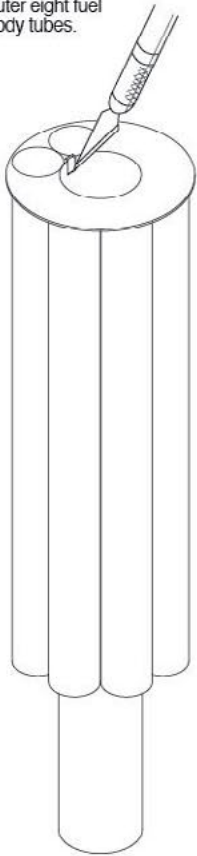

2. Apply glue inside tube at these locations.

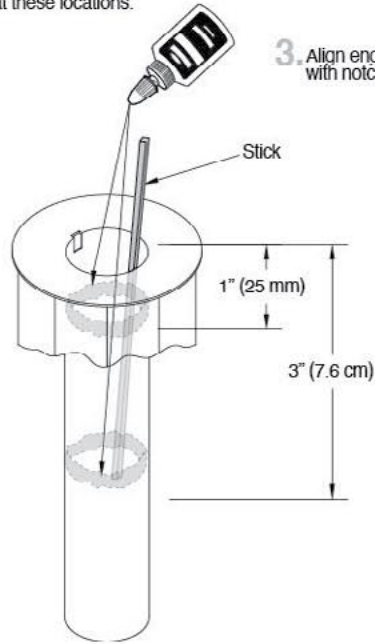

3. Align engine clip with notch.

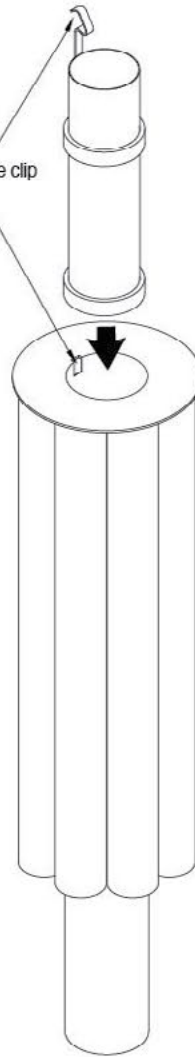

4.

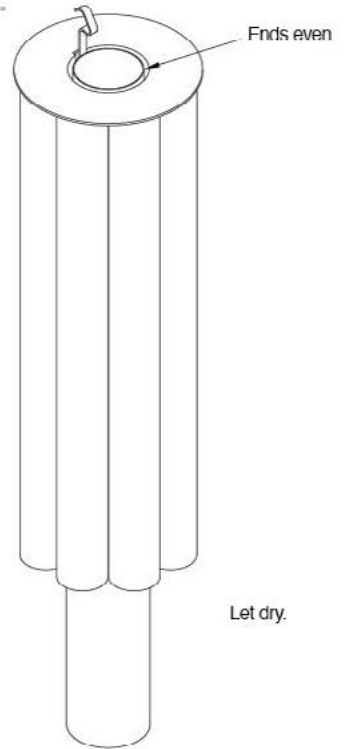

ASSEMBLE LOWER BODY SECTION

1. Apply plastic cement at base of core.

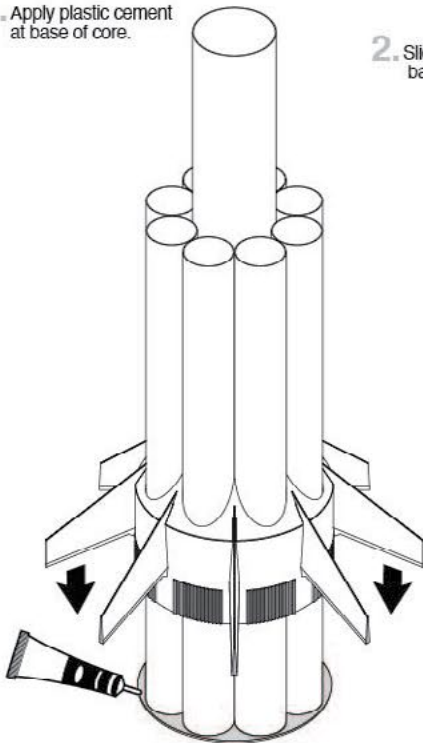

2. Slide assembly to base of core.

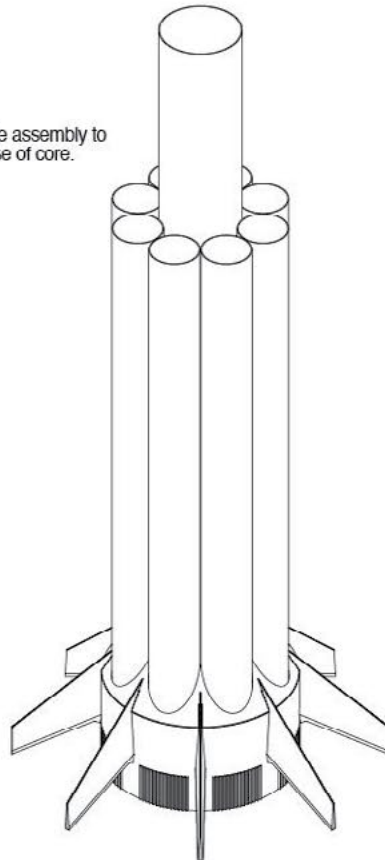

3. Apply glue fillet as indicated.

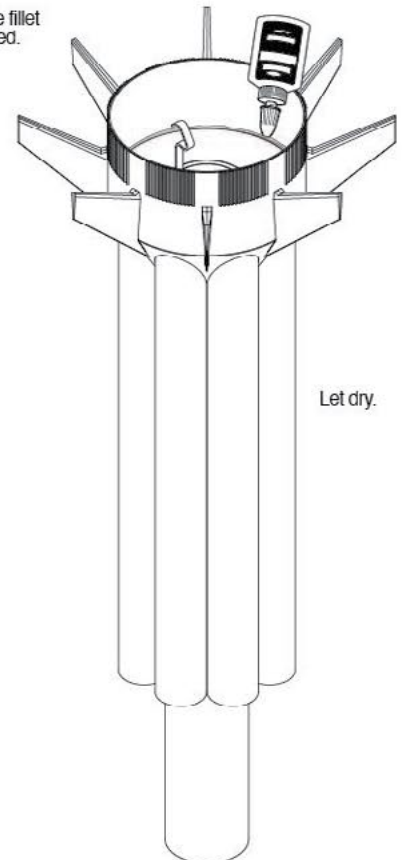

ATTACH UPPER BODY CENTERING RINGS

1.

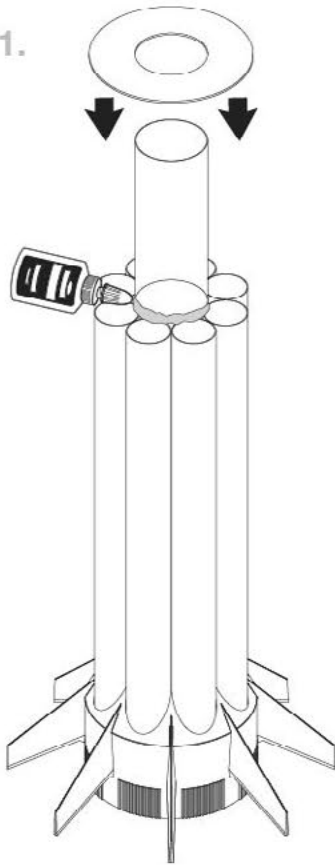

2.

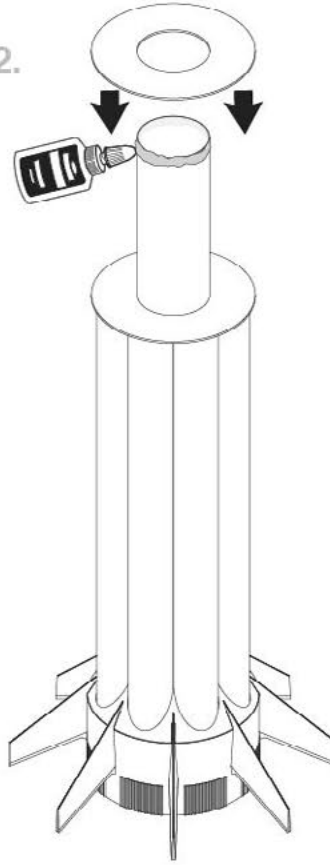

3.

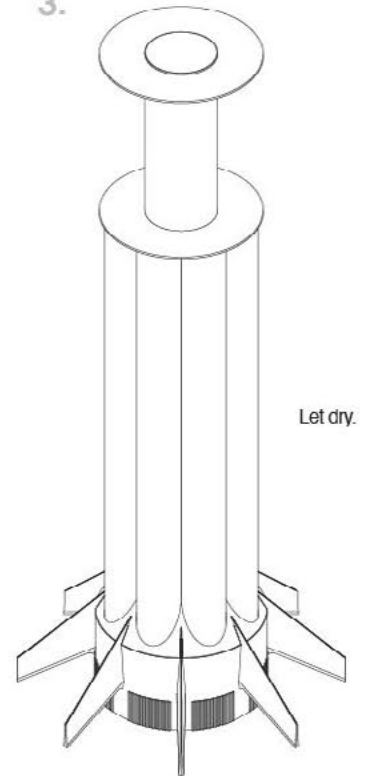

Let dry.

ATTACH UPPER BODY

1. Apply glue inside body tube at these two locations.

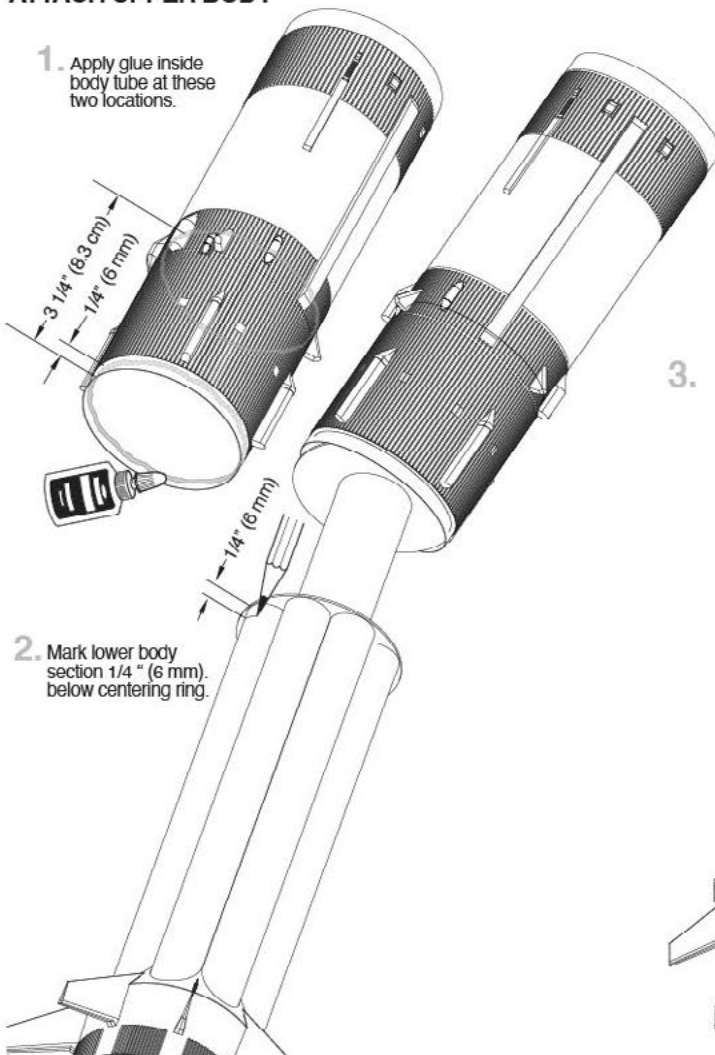

3.

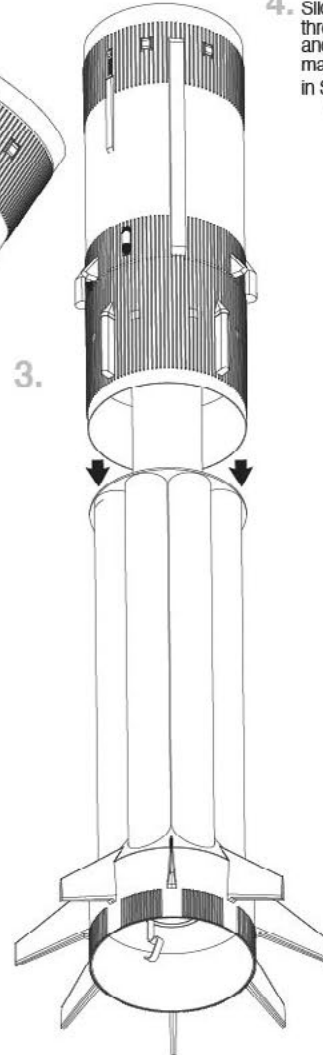

4. Slide body tube through glue and down to mark made in Step 2.

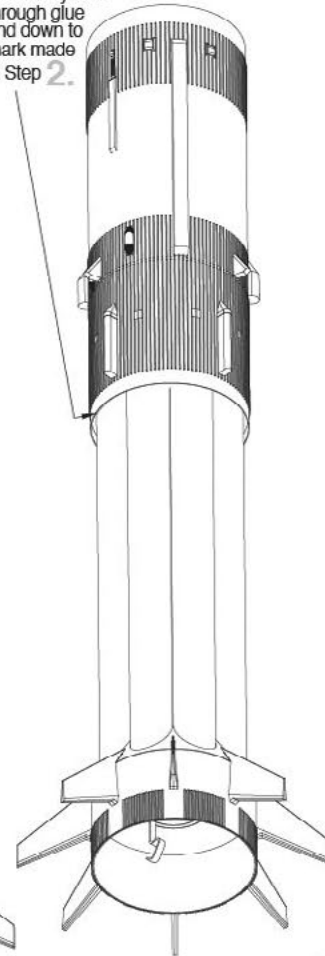

5. Align upper wrap as shown between any two tubes.

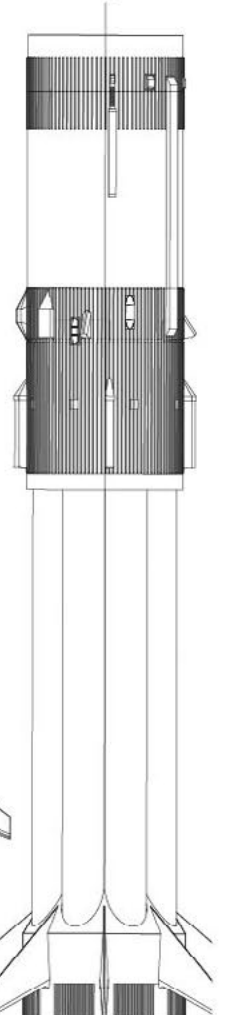

ASSEMBLE TOWER

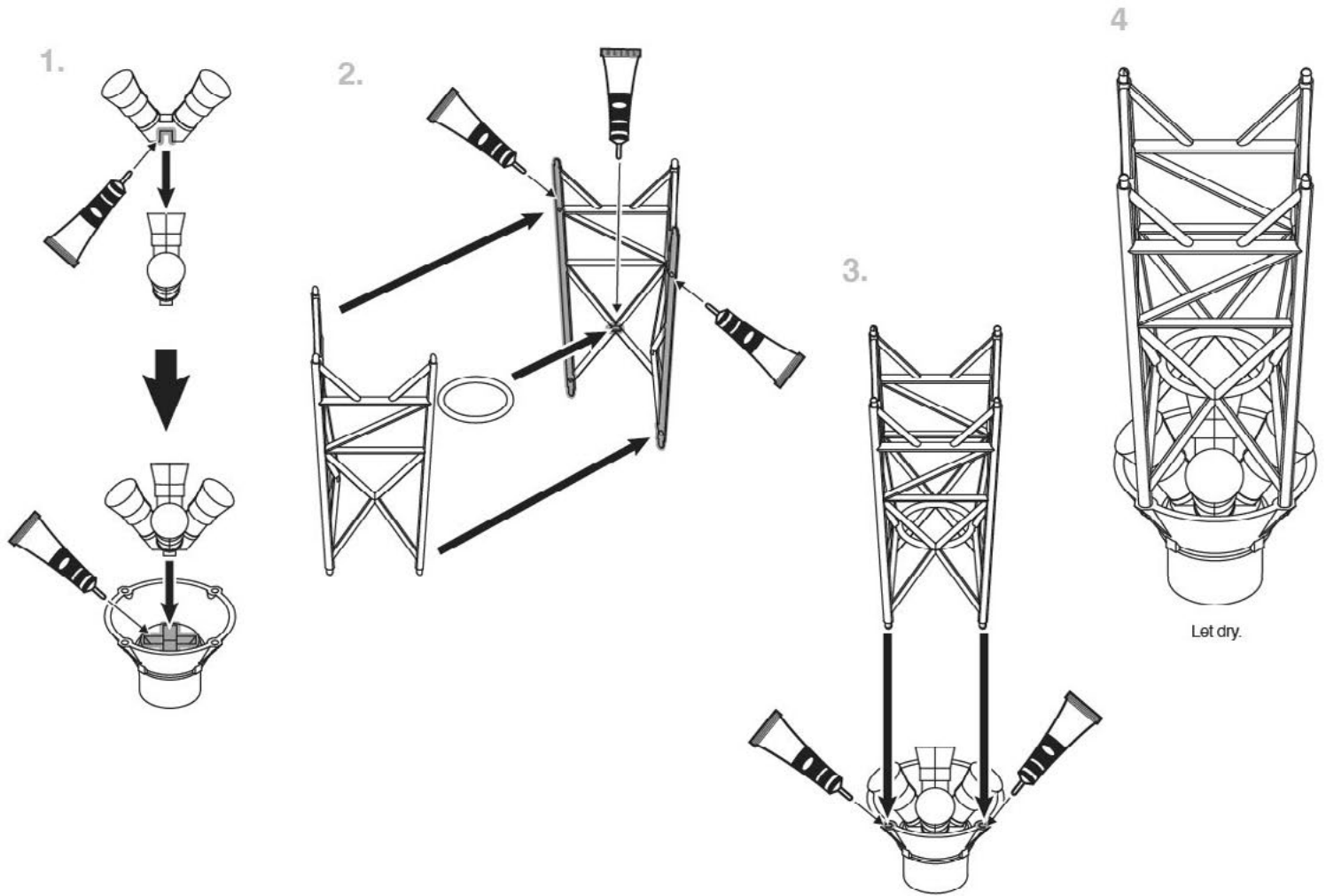

ASSEMBLE CAPSULE

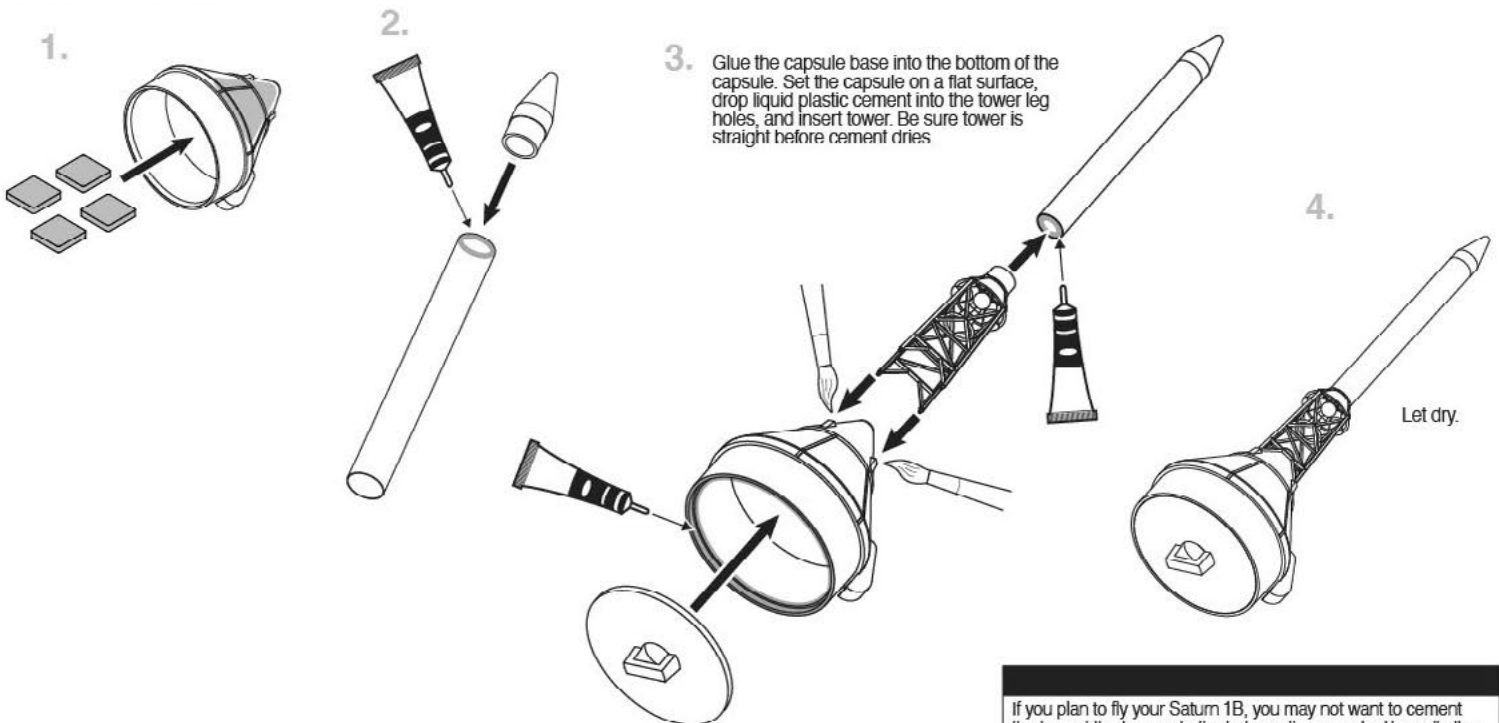

If you plan to fly your Saturn 1B, you may not want to cement the legs of the tower into the holes in the capsule. This will allow you the option of removing the fragile tower before flight.

INSTALL WIRE ANCHOR

1.

Cut from Saturn 1B Templates page.

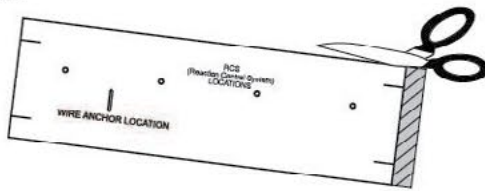

2. Masking Tape

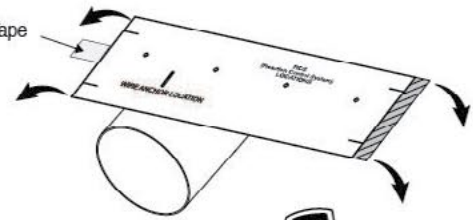

3. Cut slit for wire anchor
Rotate back and forth to create a hole at the four RCS locations.

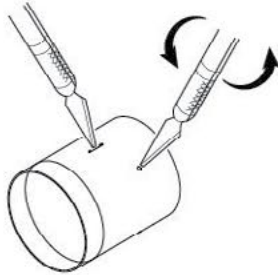

4. Remove template after holes are made in body tube.

5.

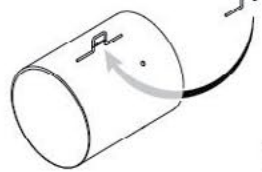

6.

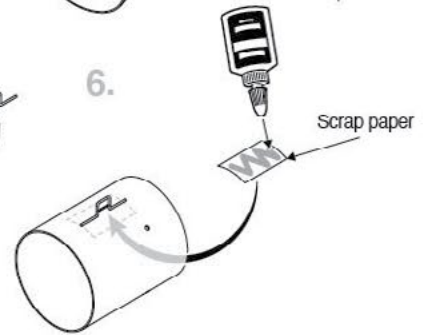

Scrap paper

7.

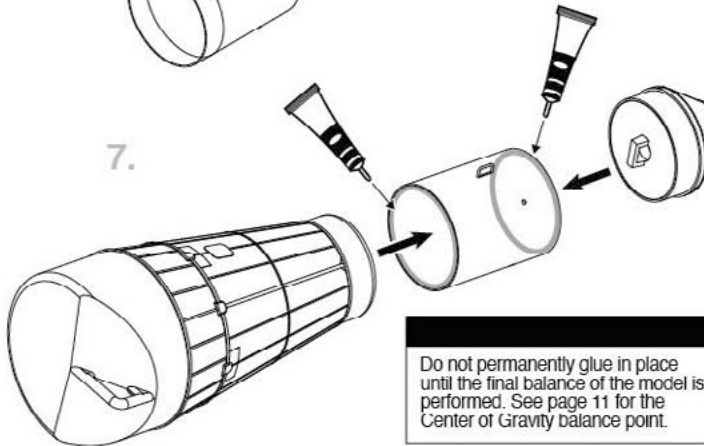

Do not permanently glue in place until the final balance of the model is performed. See page 11 for the Center of Gravity balance point.

8.

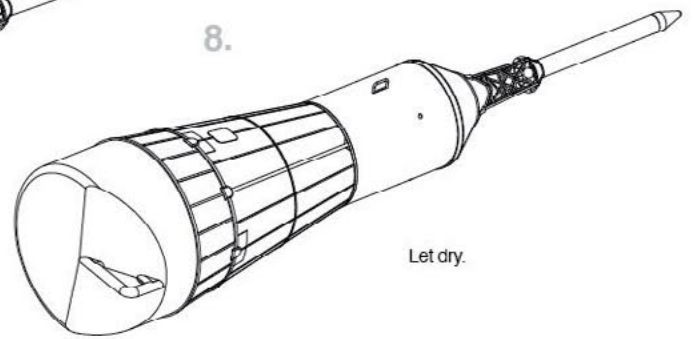

Let dry.

ATTACH LAUNCH LUGS AND DETAIL PARTS

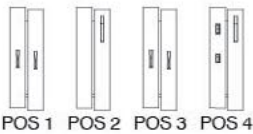

1.

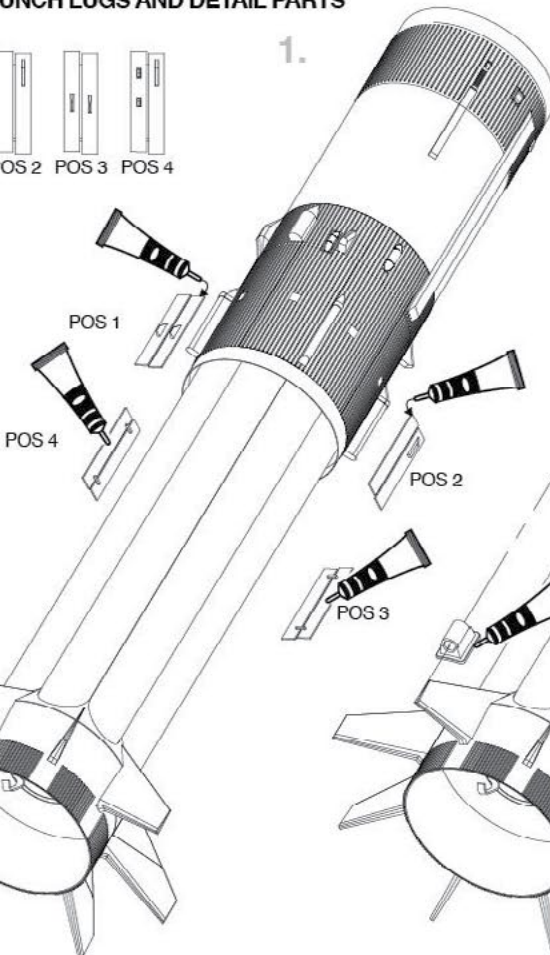

2. Confirm launch lug alignment.

3.

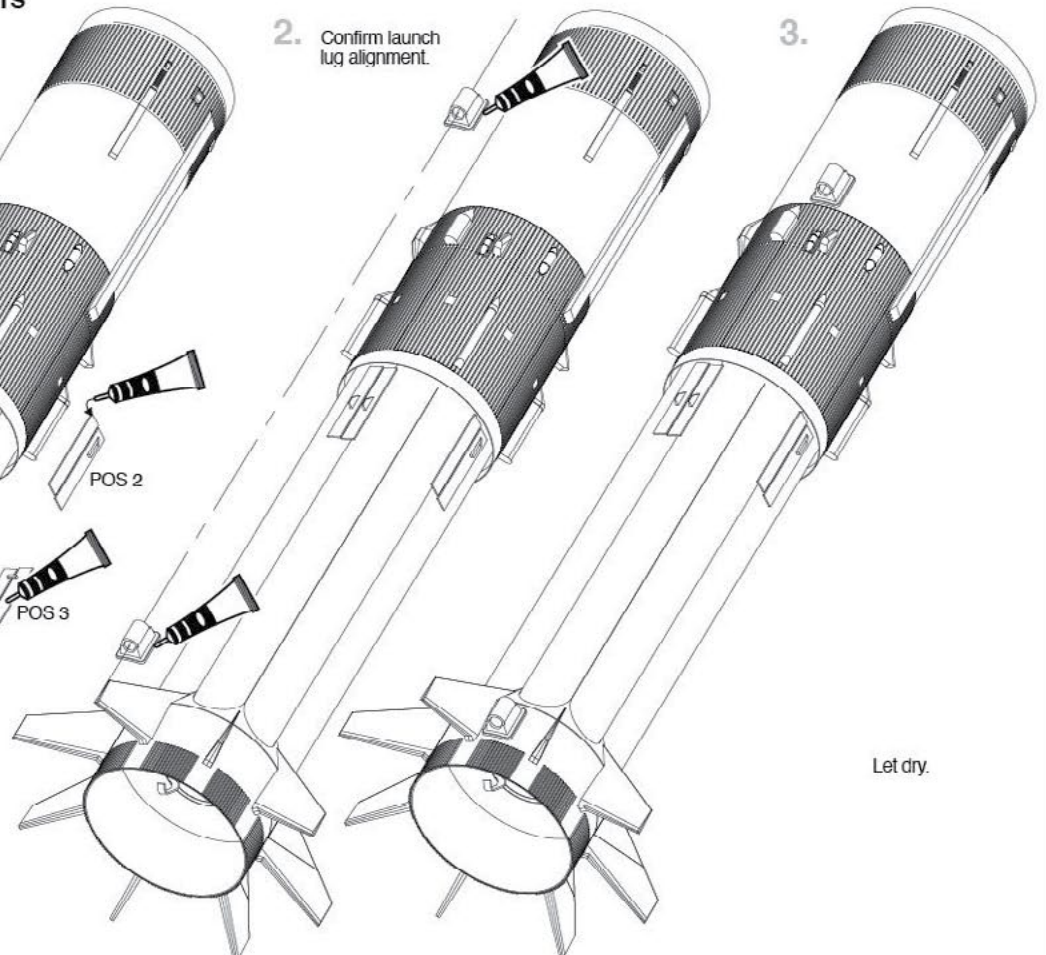

Let dry.

ASSEMBLE DISPLAY ENGINES

1. Center and glue two rings and tube as indicated.

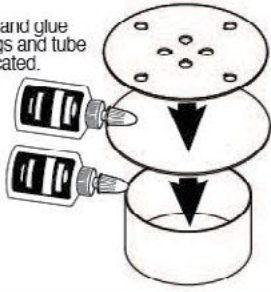

2.

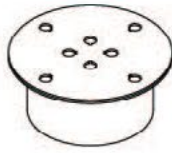

OUTER ENGINES

INNER ENGINES

3. Glue outer engines to mount with plastic cement.

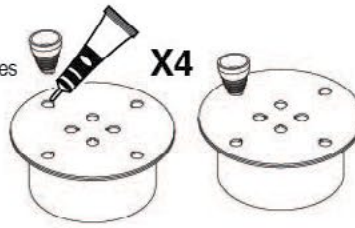

4. Repeat for inner engines.



Let dry.

PAINT ROCKET

Before painting, check that all parts are firmly attached, and that any small gaps have been filled using putty or glue. If you did not fill the spirals in the body tubes earlier, do so now. Spray adhesive can be removed with a tissue dipped in enamel thinner (use sparingly!), and wood glue or CA can be removed using a fine grain sandpaper. If you do not wish to mask off the model, you may spray the entire model white, then use bottle paint for the black and silver (or gunmetal) areas. Again, **DO NOT USE LACQUER BASED PAINTS.** They will attack the plastic parts of your Saturn 1B. If you have any doubt about the paints you wish to use, use a piece of scrap plastic as a test surface.

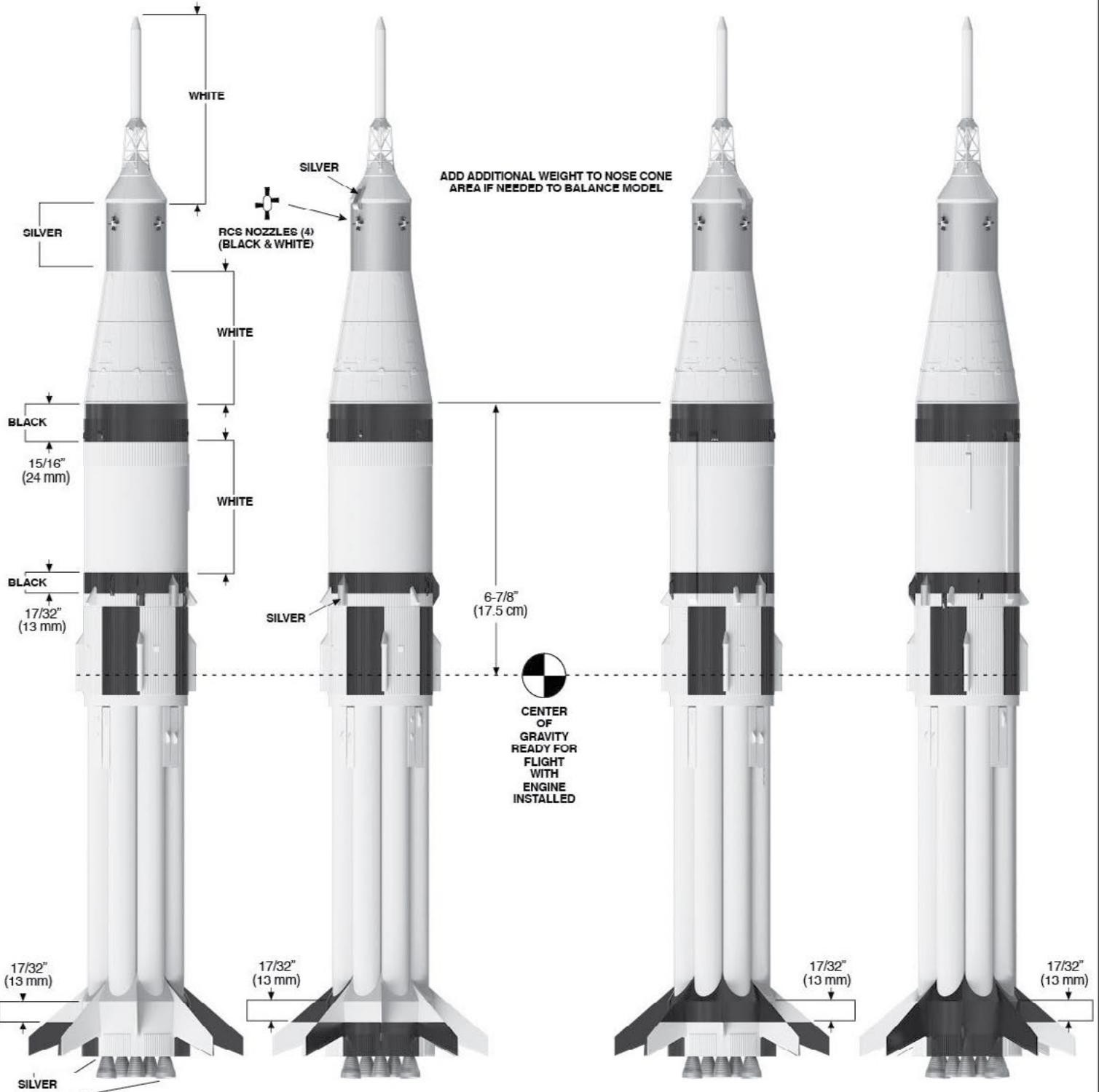

APPLY DECALS

1. Cut out one decal at a time from the sheet. Soak the decals, one at a time, in warm water for 15-30 seconds until decal will slide easily from the backing paper. Transfer the decal to the model, and gently blot away excess water and air bubbles with a soft cloth.

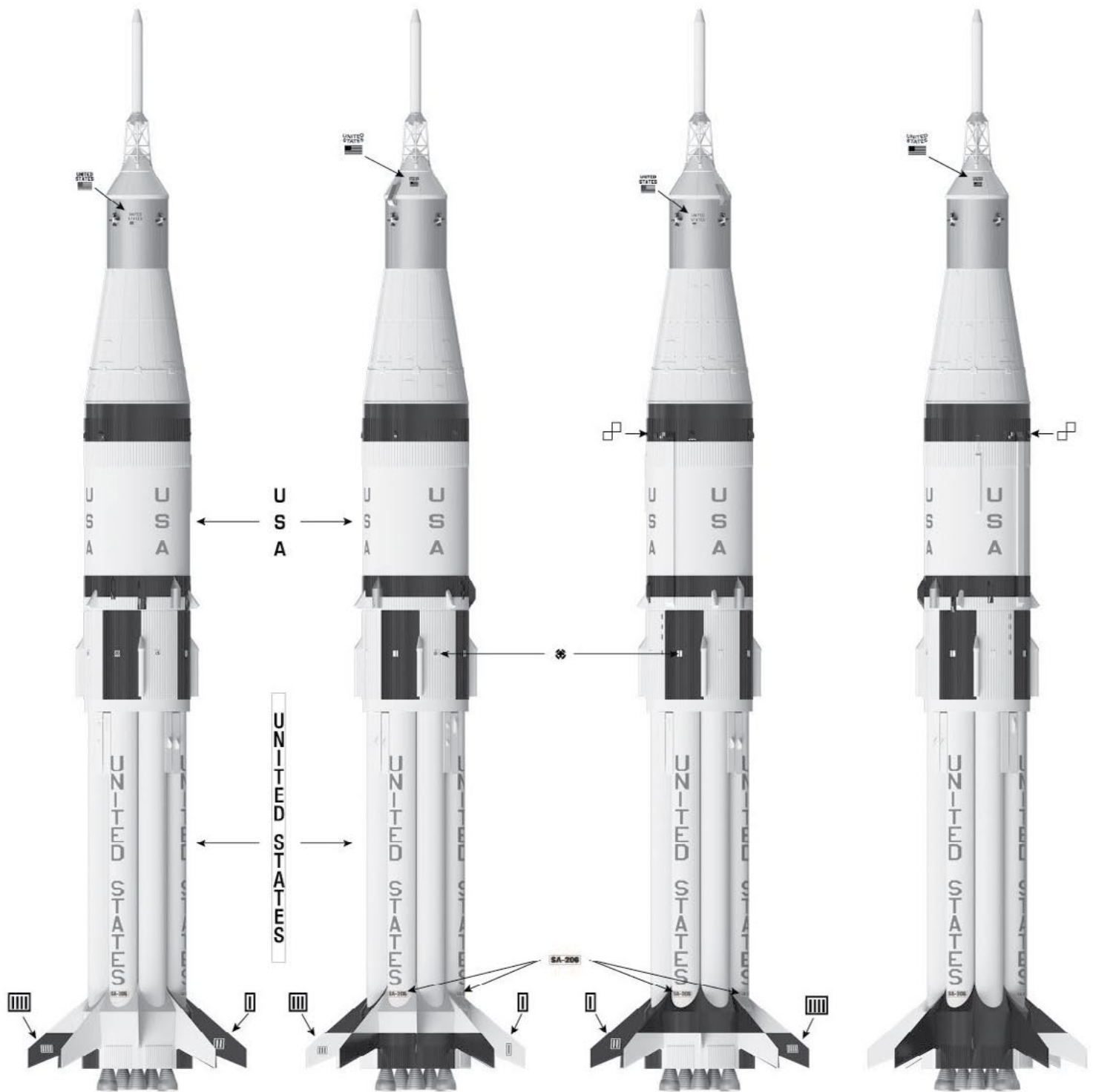

2. The "USA" and "United States" decals are centered vertically within the paint patterns, and horizontally between the body wraps. Measure and place light tic marks to help you properly orient decals. Raised squares on the second stage and reduction wraps provide locations for the camera and target decals.
3. Finish by painting the entire model with a flat clear coat.

ATTACH SHOCK CORD

1. Cut out the shock cord mount on Saturn 1B Templates page.

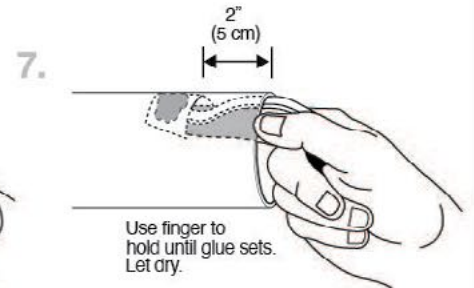
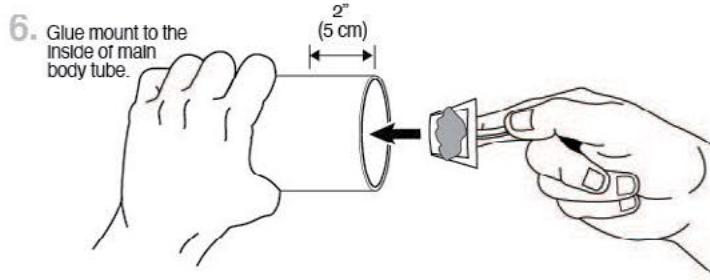
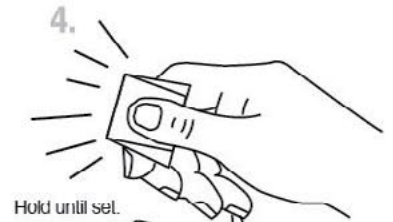
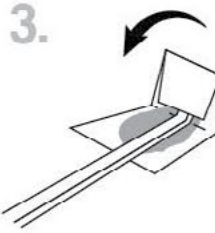
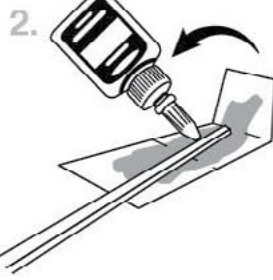
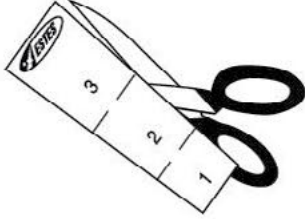

PREPARE RECOVERY SYSTEM

1. Form a loop in the shroud lines of the 18" (45.7 cm) parachute.

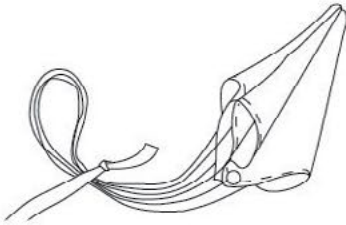

2. Lay the knotted end of the shock cord over loop.

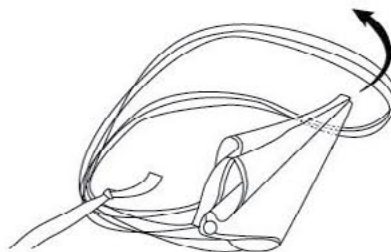

3. Pass parachute through loop and pull tight.

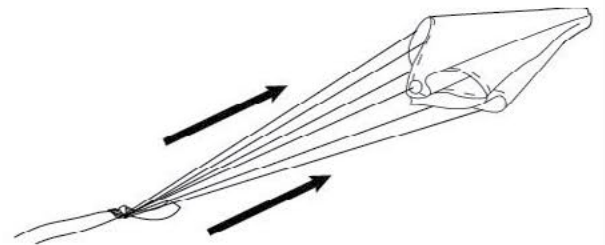

PREPARE UPPER STAGE RECOVERY SYSTEM

1. Form a loop with the shroud lines on the 15" (38.1 cm) parachute, and tie the remaining shock cord to the loop with a double knot.

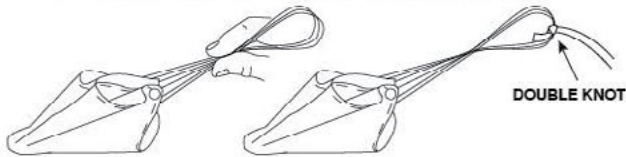

2. Tie the free end of the shock cord to the loop at the rear of the LEM shroud.

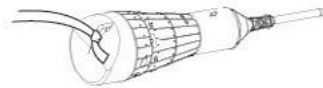

3. Measure a 13" (33 cm) piece from the shroud line material and tie one end to the snap swivel.



4. Tie the other end of the line to the shock cord 15" (38.1 cm) from the rear of the third stage, then knot the shock cord over the line.

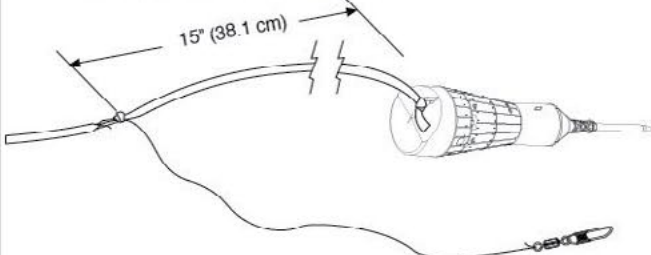

5. Snap the front of the snap swivel onto the wire anchor at the top of the LEM (The snap swivel allows you to detach this portion of the recovery system and pack into the body tube for display.) Unhook for painting.

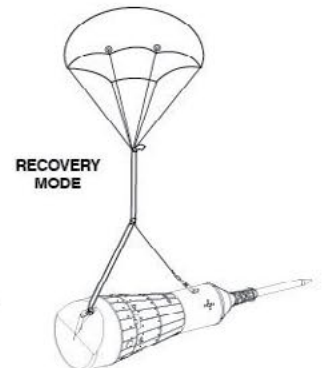
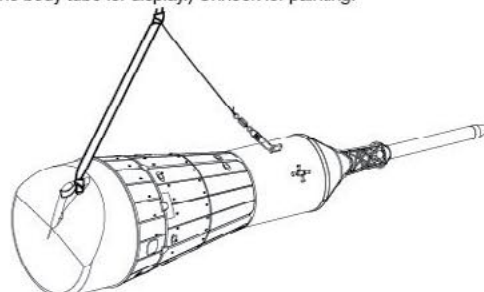

PREPARE FLIGHT RECOVERY

1. Crumple and place four squares of recovery wadding into the front of engine mount tube.
2. Push four squares of recovery wadding in the bottom of parachute compartment.
3. Spike, fold, and roll the 18" (45.7 cm) parachute and insert into parachute compartment.
4. Lay two squares of recovery wadding on top of parachute.
5. Attach the snap swivel to the wire anchor. Spike, fold and roll the 15" (38.1 cm) parachute, and lay parachute on the wadding in the middle of the parachute compartment. Insert the forward section into the main body tube, and twist back and forth to make sure the sections do not bind.

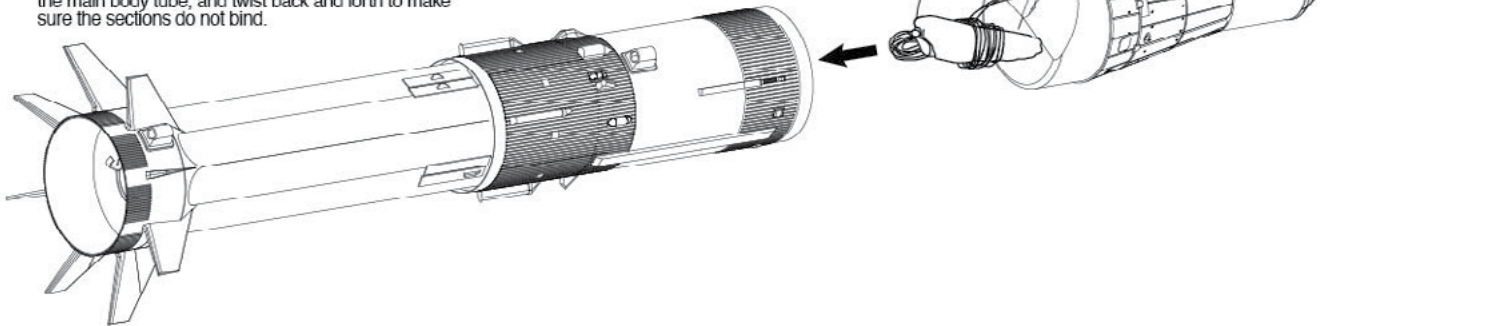

PREPARE ENGINE

1. ENGINE
2. Use 1 each. STARTER PLUG
3. TIP MUST TOUCH PROPELLANT!
- 4.
- 5.

To avoid serious injury, read instructions & NAR Safety Code included with engines. **PREPARE YOUR ENGINE ONLY WHEN YOU ARE OUTSIDE AT THE LAUNCH SITE PREPARING TO LAUNCH.** If you do not use your prepared engine, remove the starter before storing your engine.

SEE OUR ENTIRE FLEET OF SCALE KITS AT
EstesRockets.com



2056
U.S. Army Patriot M-104



3228
V2



1293
Black Brant III



1921
Mercury Redstone 4
Liberty Bell 7



7000
Bull Pup 12-D



7255
Little Joe I



9720
Doorknob



2446
Mini Honest John

Rockets not to scale with each other.

COUNTDOWN AND LAUNCH

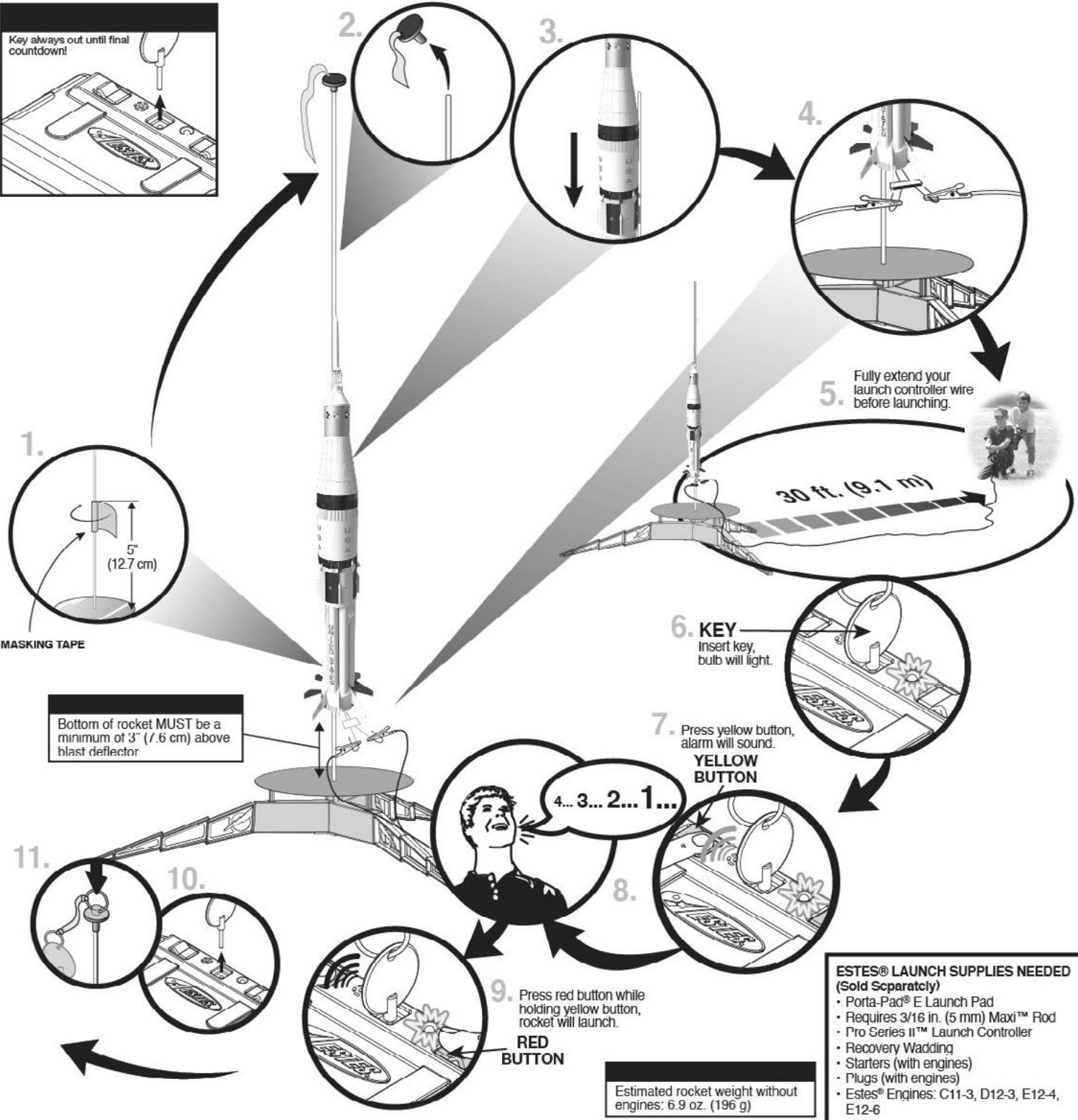

- ESTES® LAUNCH SUPPLIES NEEDED (Sold Separately)**
- Porta-Pad® E Launch Pad
 - Requires 3/16 in. (5 mm) Maxi™ Rod
 - Pro Series II™ Launch Controller
 - Recovery Wadding
 - Starters (with engines)
 - Plugs (with engines)
 - Estes® Engines: C11-3, D12-3, E12-4, E12-6

PRECAUTIONS



NAR SAFETY CODE



NO DRY GRASS OR WEEDS

PRE-LAUNCH CHECK For safety, never launch a damaged rocket. Check the rocket's body, nose cone and fins. Also, check the engine mount, recovery system and launch lug(s). Repair any damage before launching the rocket.

FLYING YOUR ROCKET Choose a large field (500 ft [152 m] square) free of dry weeds and brown grass. The larger the launch area, the better your chance of recovering your rocket. Football fields and playgrounds are great. Launch only with little or no wind and good visibility. Always follow the National Association of Rocketry (NAR) SAFETY CODE.

MISFIRES TAKE THE KEY OUT OF THE CONTROLLER. WAIT ONE MINUTE BEFORE GOING NEAR THE ROCKET. Disconnect the micro-clips and remove the engine. Take the plug and starter out of the engine. A burned starter means the starter tip is not touching engine propellant. Install a new starter; be sure the tip is touching propellant inside the engine. Push the plug in place. Repeat steps under Countdown and Launch.

