

ROCKET FINISHING CONTINUED

6. Apply 2 light coats of white primer to upper rocket section. Allow to dry and lightly sand with fine sandpaper (#320 or #400 grit) between coats.
7. Spray paint entire lower rocket section gloss black.
 - a. Allow to dry overnight (24 hours is best).
8. Cover **L** with masking tape. Spray paint upper rocket section Testors Fiery Orange.
 - a. Allow to dry overnight (24 hours is best). Remove tape.
9. Apply masking tape and protective covering over Fiery Orange and to shoulder of **L**. Spray tube adapter area gloss black.
 - a. Allow to dry overnight (24 hours is best). Remove tape.
10. Apply waterslide decals where shown.
 - a. Cut decals to be applied from decal sheet, trimming close to the decal edge.
 - b. Place decal in bowl of warm water until decal begins to curl.
 - c. Remove decal, position in place and slide decal off of backing material and onto the model as close to final position as possible.
 - d. Gently blot excess water with a clean paper towel. Allow decals to set overnight.
 - e. Apply protective clear coat, optional. This will provide added protection and shine to your Vector Force™ rocket!

RECOVERY SYSTEM ATTACHMENT

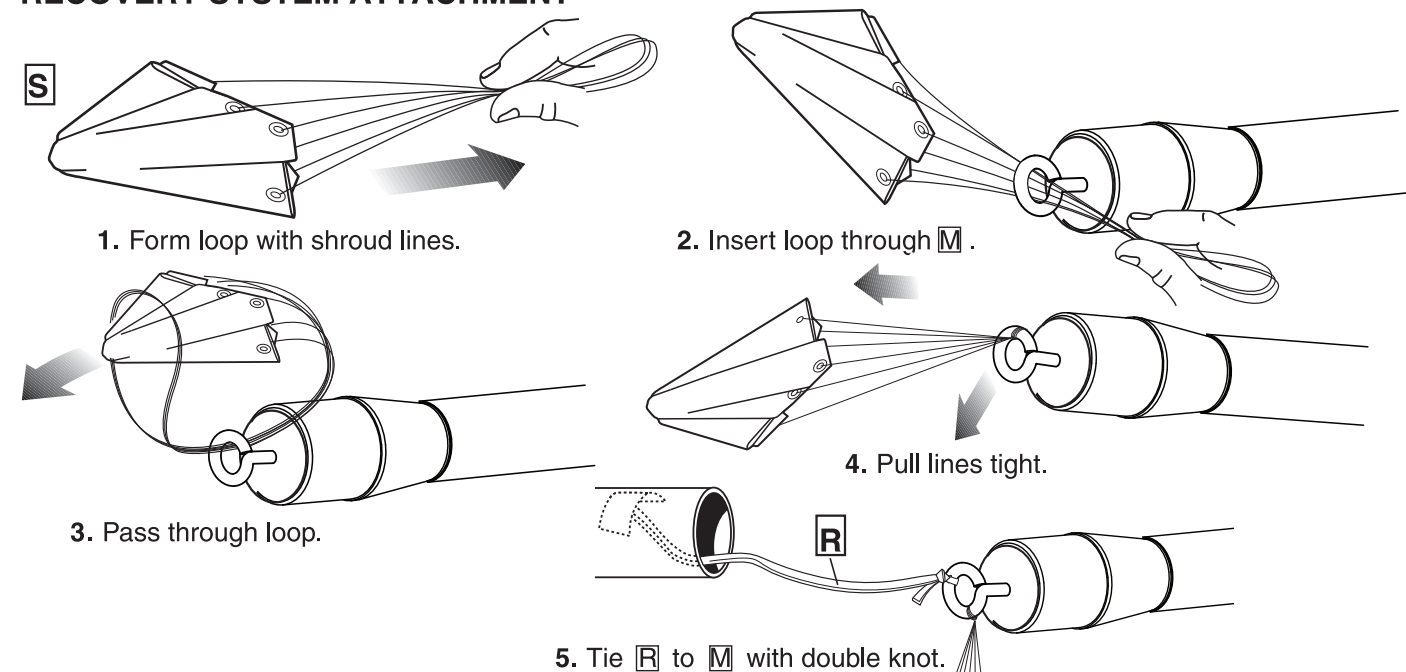

FLIGHT RECOVERY PREPARATION

NOTE: Only Estes Recovery Wadding (302274) recommended.

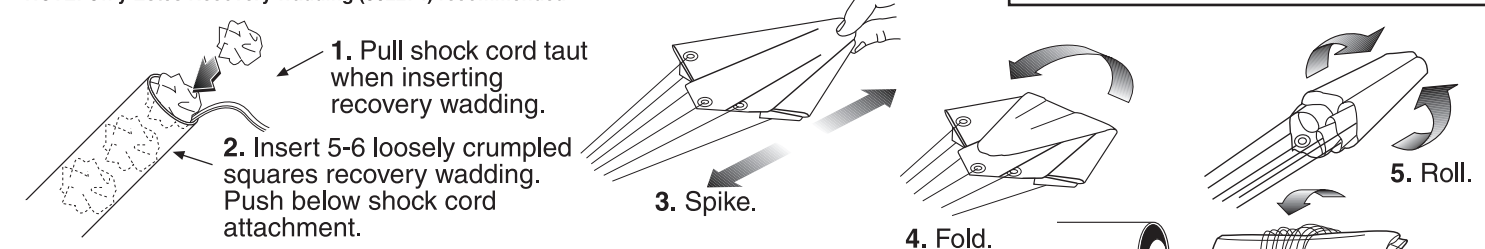

NOTE: Recovery wadding and parachute must slide easily into body tube. If too tight, redo.

ENGINE PREPARATION

WARNING: FLAMMABLE

To avoid serious injury, read instructions & NAR Safety Code included with engines.
PREPARE ENGINE ONLY WHEN YOU ARE OUTSIDE AT THE LAUNCH SITE PREPARING TO LAUNCH!
 If you do not use your prepared engine, remove the igniter before storing engine.

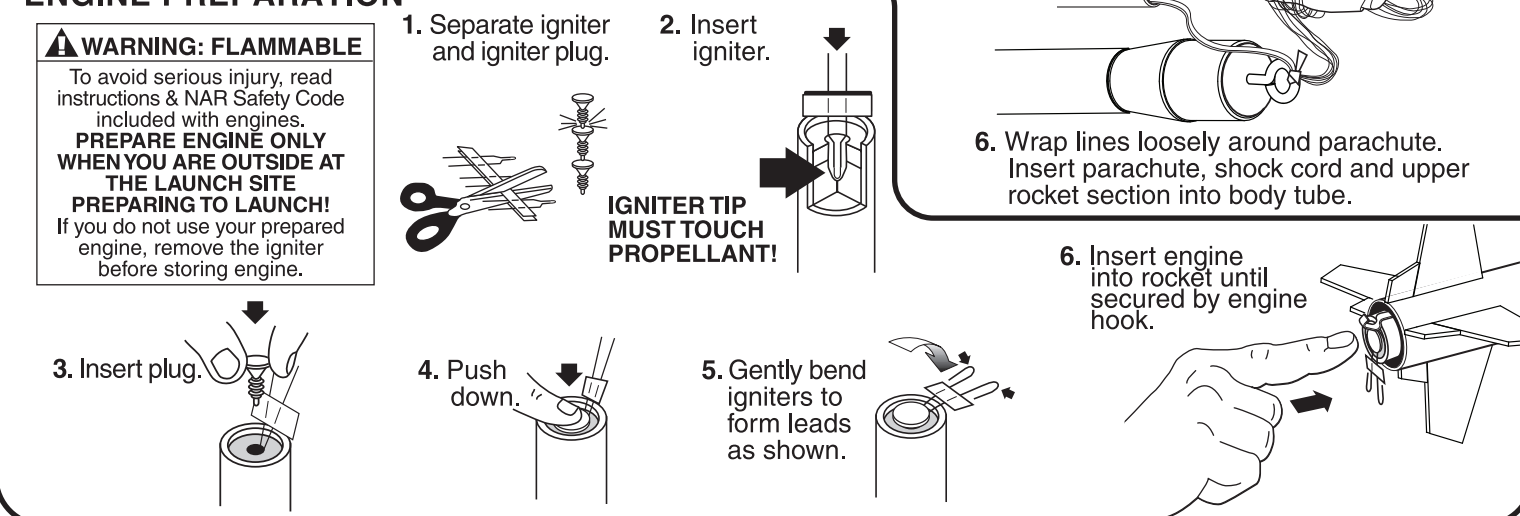

COUNTDOWN AND LAUNCH

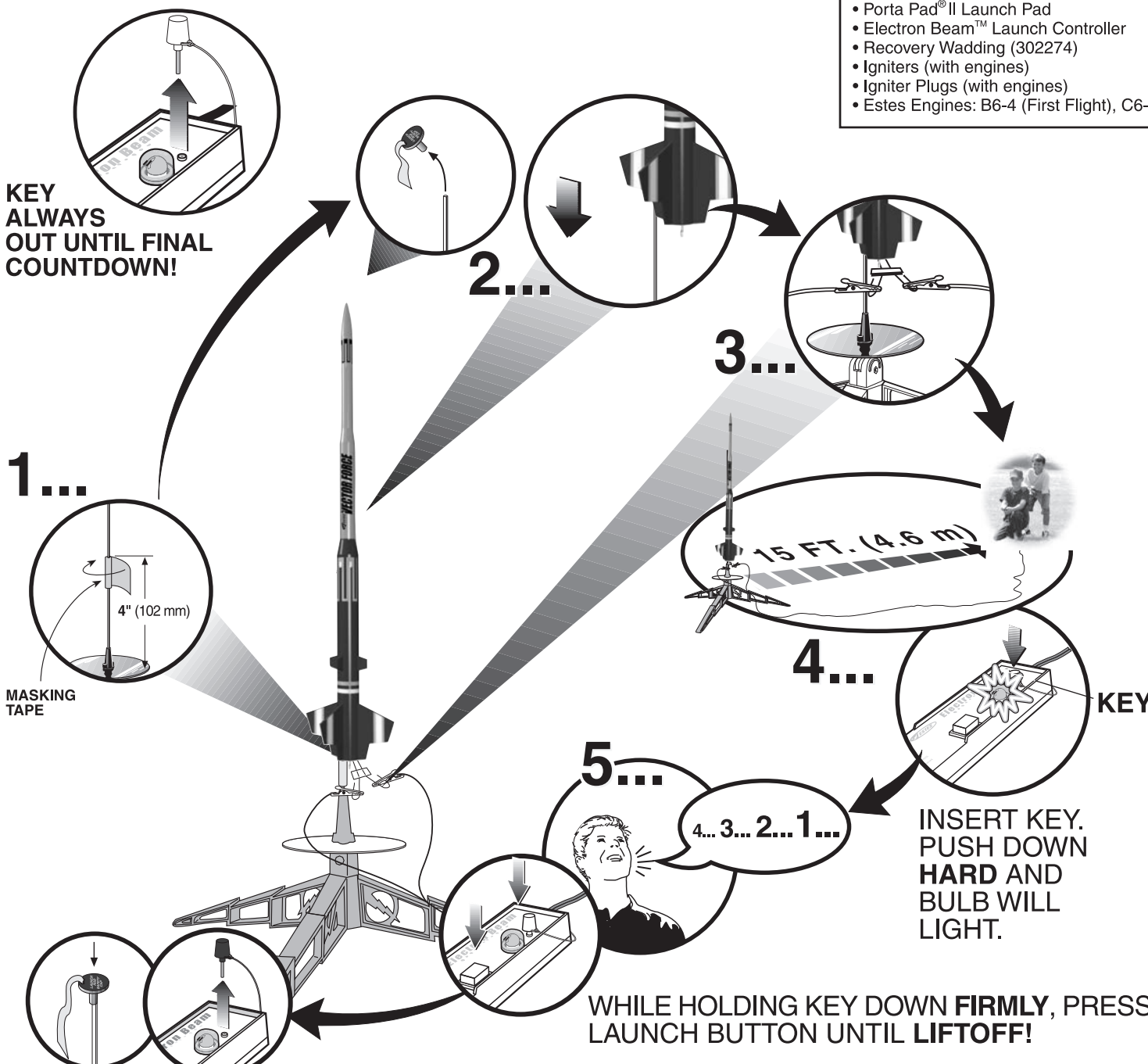

ESTES LAUNCH SUPPLIES NEEDED (Sold Separately)

- Porta Pad® II Launch Pad
- Electron Beam™ Launch Controller
- Recovery Wadding (302274)
- Igniters (with engines)
- Igniter Plugs (with engines)
- Estes Engines: B6-4 (First Flight), C6-5

PRECAUTIONS

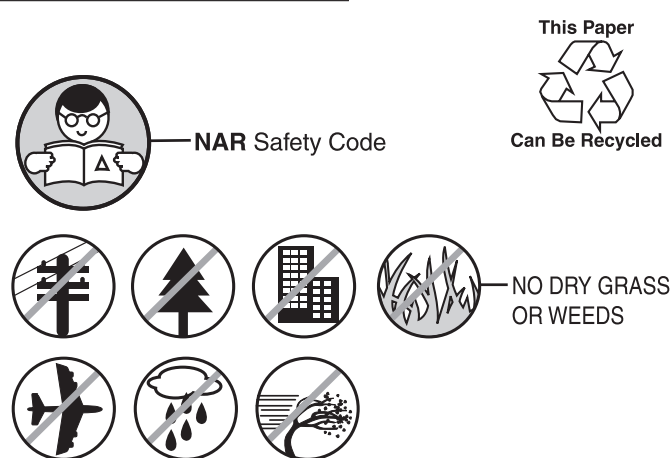

PRE-LAUNCH CHECK

For safety, never launch a damaged rocket. Check the rocket's body, nose cone and fins. Also, check the engine mount, recovery system and launch lug. Repair any damage before launching the rocket.

FLYING YOUR ROCKET

Choose a large field (500 ft. [153 m] square) free of dry weeds and brown grass. The larger the launch area, the better your chance of recovering your rocket. Football fields and playgrounds are great. Launch only with little or no wind and good visibility.

Always follow the National Association of Rocketry (NAR) SAFETY CODE.

MISFIRES

TAKE THE KEY OUT OF THE CONTROLLER. WAIT ONE MINUTE BEFORE GOING NEAR THE ROCKET! Disconnect the igniter clips and remove the engine. Take the plug and igniter out of the engine. If the igniter has burned, it worked but did not ignite the engine because it was not touching the propellant inside the engine. Put a new igniter all the way inside the engine without bending it. Push the plug in place. Repeat the steps under Countdown and Launch.



Estes-Cox Corp.
 1295 H Street, PO Box 227
 Penrose, CO 81240-0227
 Printed in Guangdong, China

VECTOR FORCE™

FLYING MODEL ROCKET KIT INSTRUCTIONS

KEEP FOR FUTURE REFERENCE

#3210

ASSEMBLY TIP: Read all instructions before beginning work on your model. Make sure you have all parts and supplies.



www.estesrockets.com

NOTE: Test fit all parts together before applying glue. If parts don't fit properly, sand as required for precision assembly.

IMPORTANT: Your Estes product is marked with a four digit lot code or codes. The code is two digits, a space and two more digits representing the week and year of manufacture, respectively. Lot codes can be found on the product package, decal, launch controller, launch pad and/or blast deflector. Please record the lot code found on the decal and keep for future reference. Lot code: _____

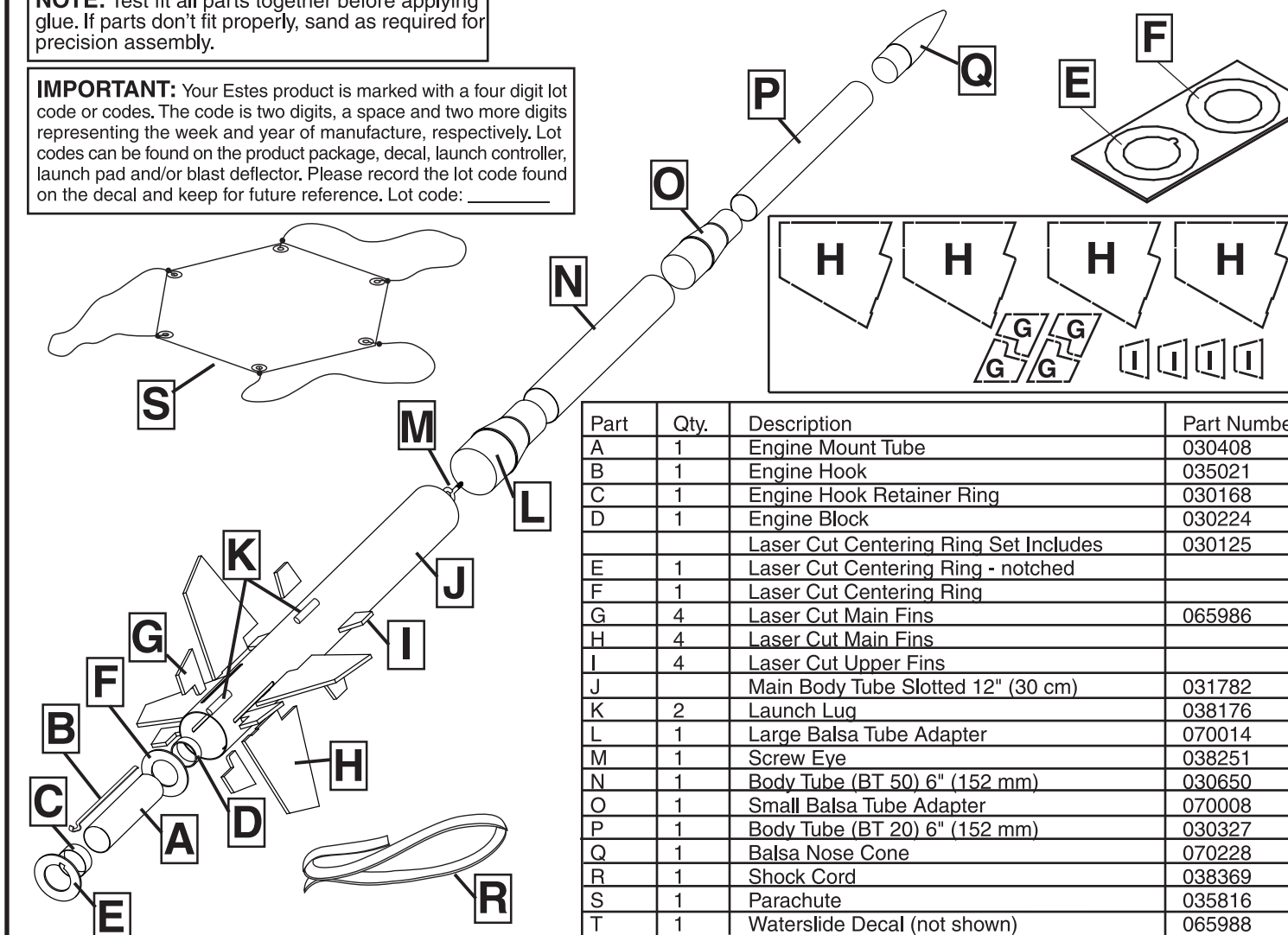

SUPPLIES

In addition to the parts included in the kit you will also need:

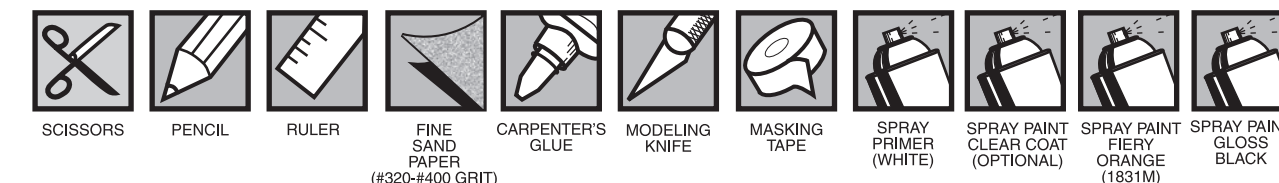

TUBE MARKING GUIDE AND SHOCK CORD MOUNT

(Make a copy if you want to keep instructions.)

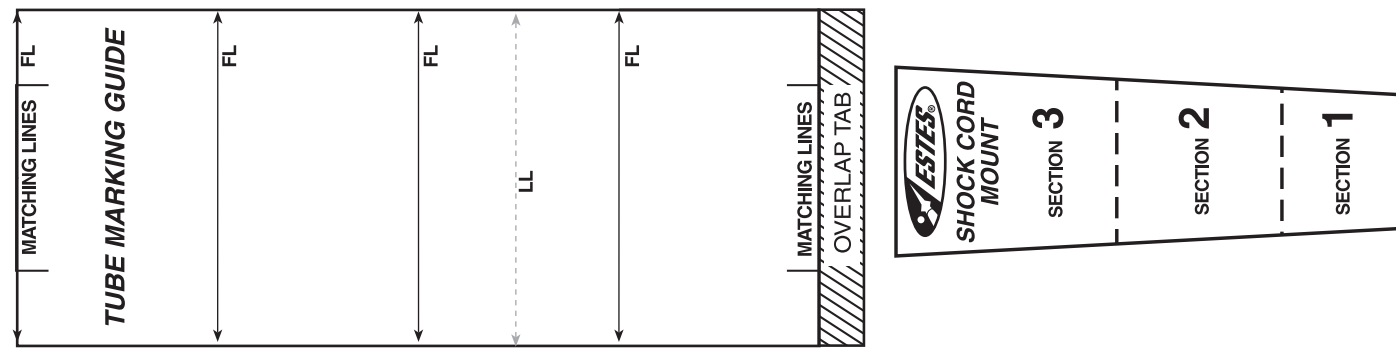

TUBE MARKING

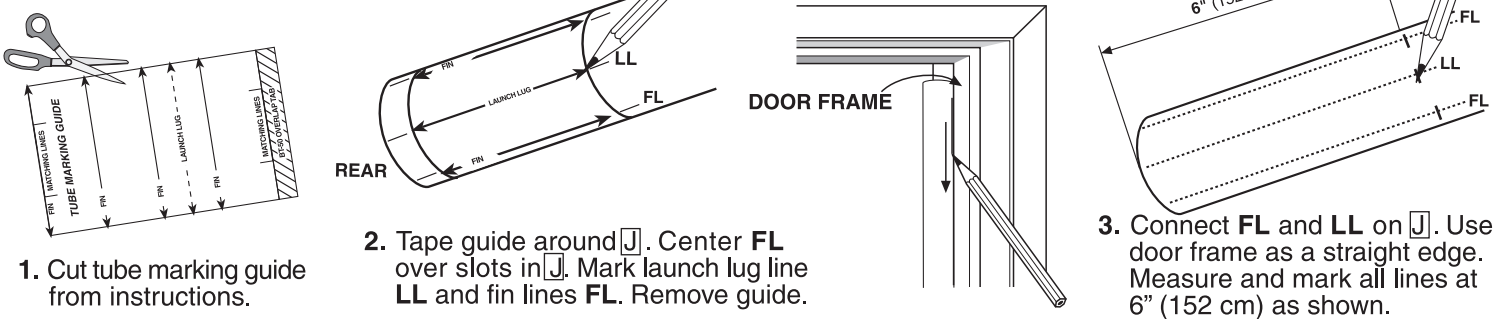

FIN PREPARATION

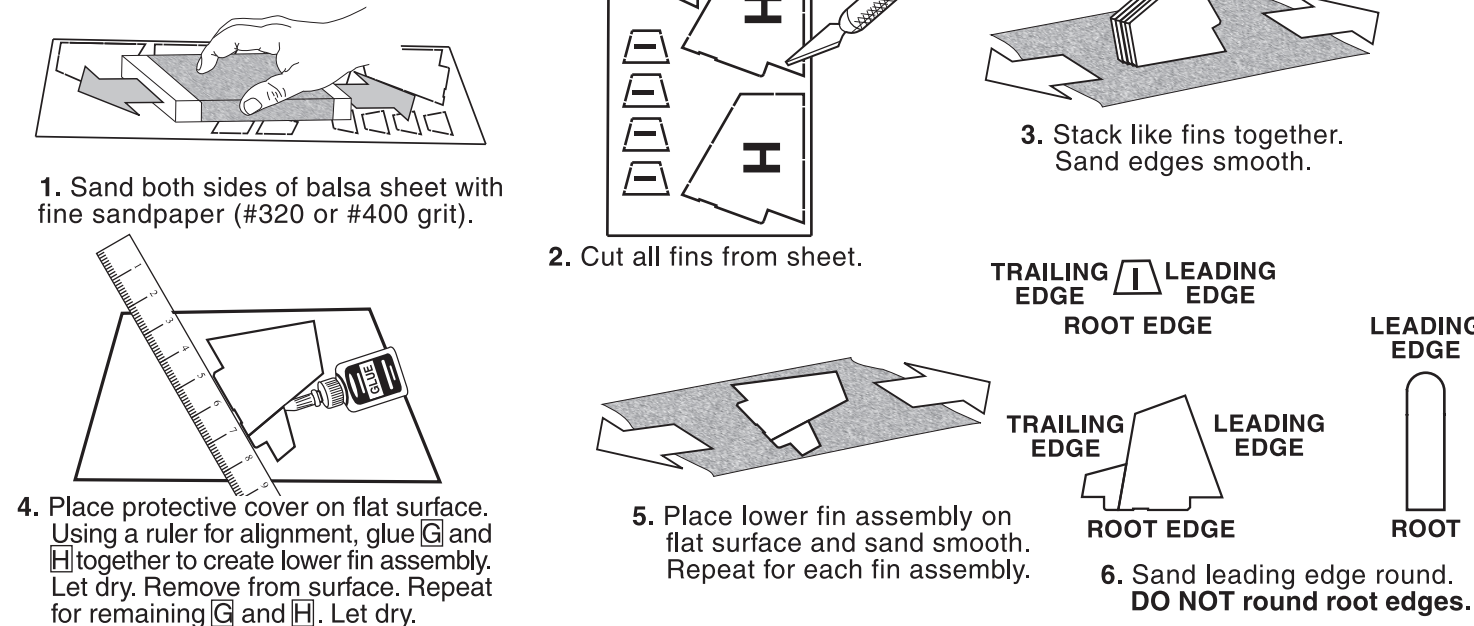

ENGINE MOUNT ASSEMBLY

NOTE: For the assembled fins to fit properly, it is very important to measure, mark and assemble the ENGINE MOUNT carefully.

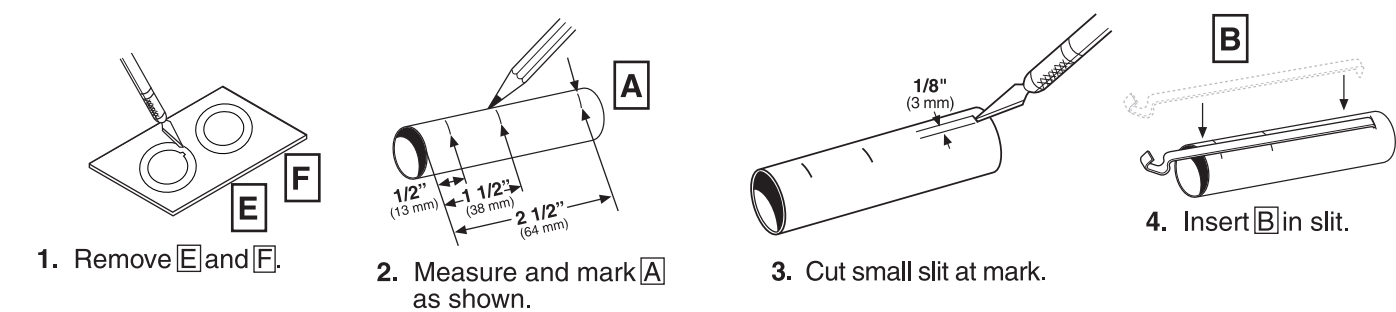

ENGINE MOUNT ASSEMBLY CONTINUED

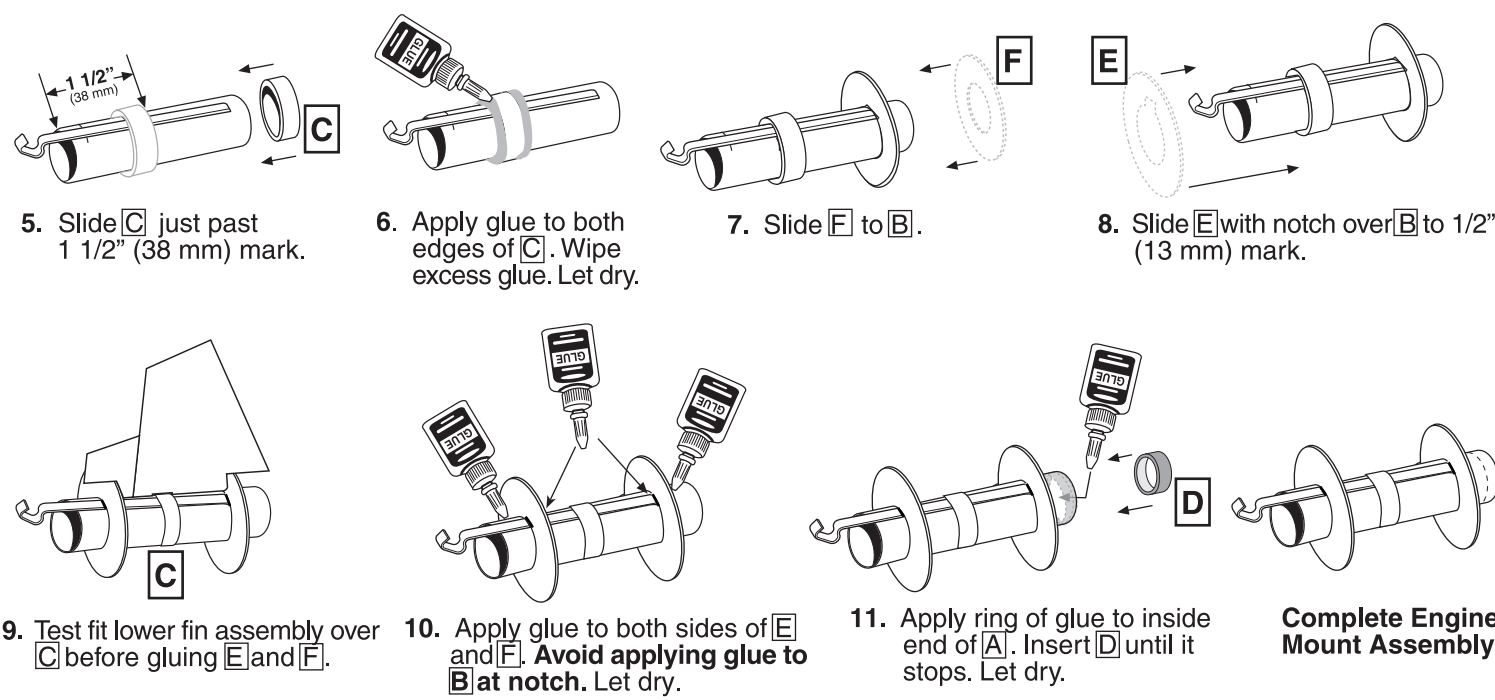

ENGINE MOUNT INSTALLATION

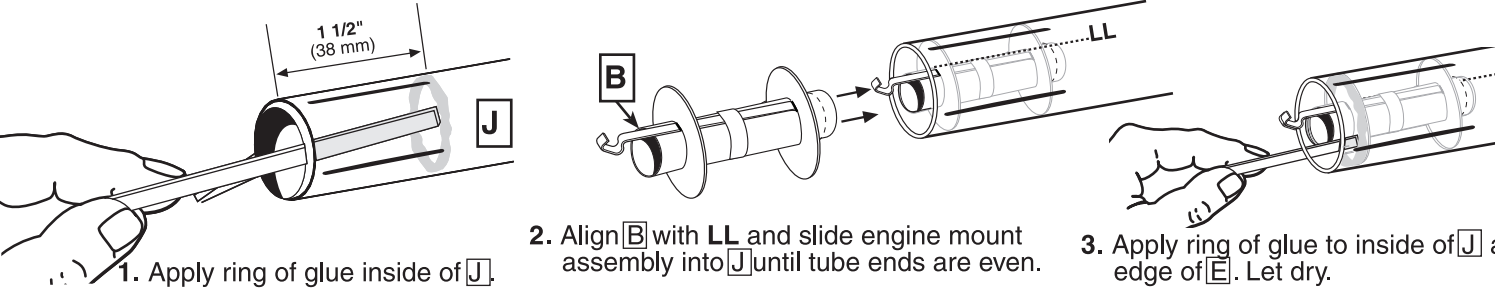

MAIN FIN ATTACHMENT

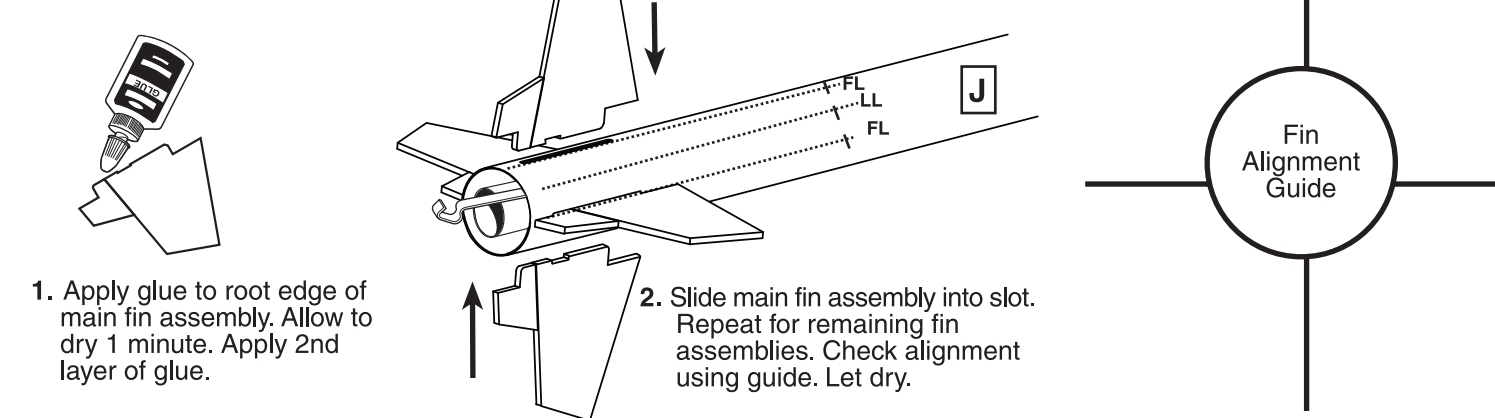

UPPER FIN ATTACHMENT

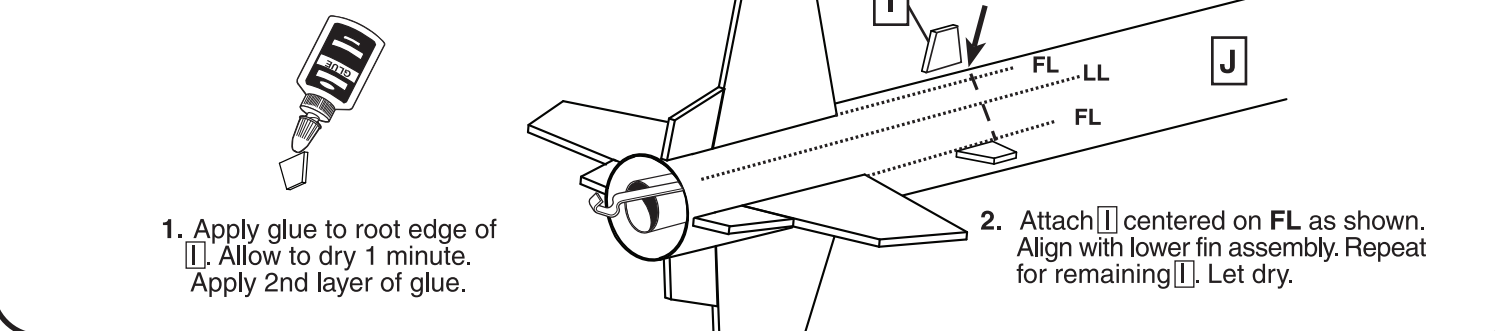

LAUNCH LUG ATTACHMENT

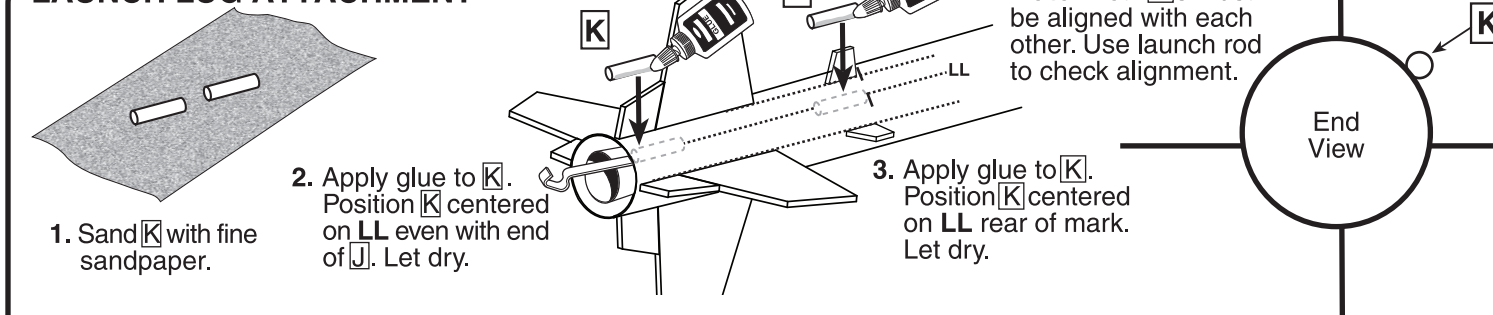

UPPER BODY TUBE ASSEMBLY

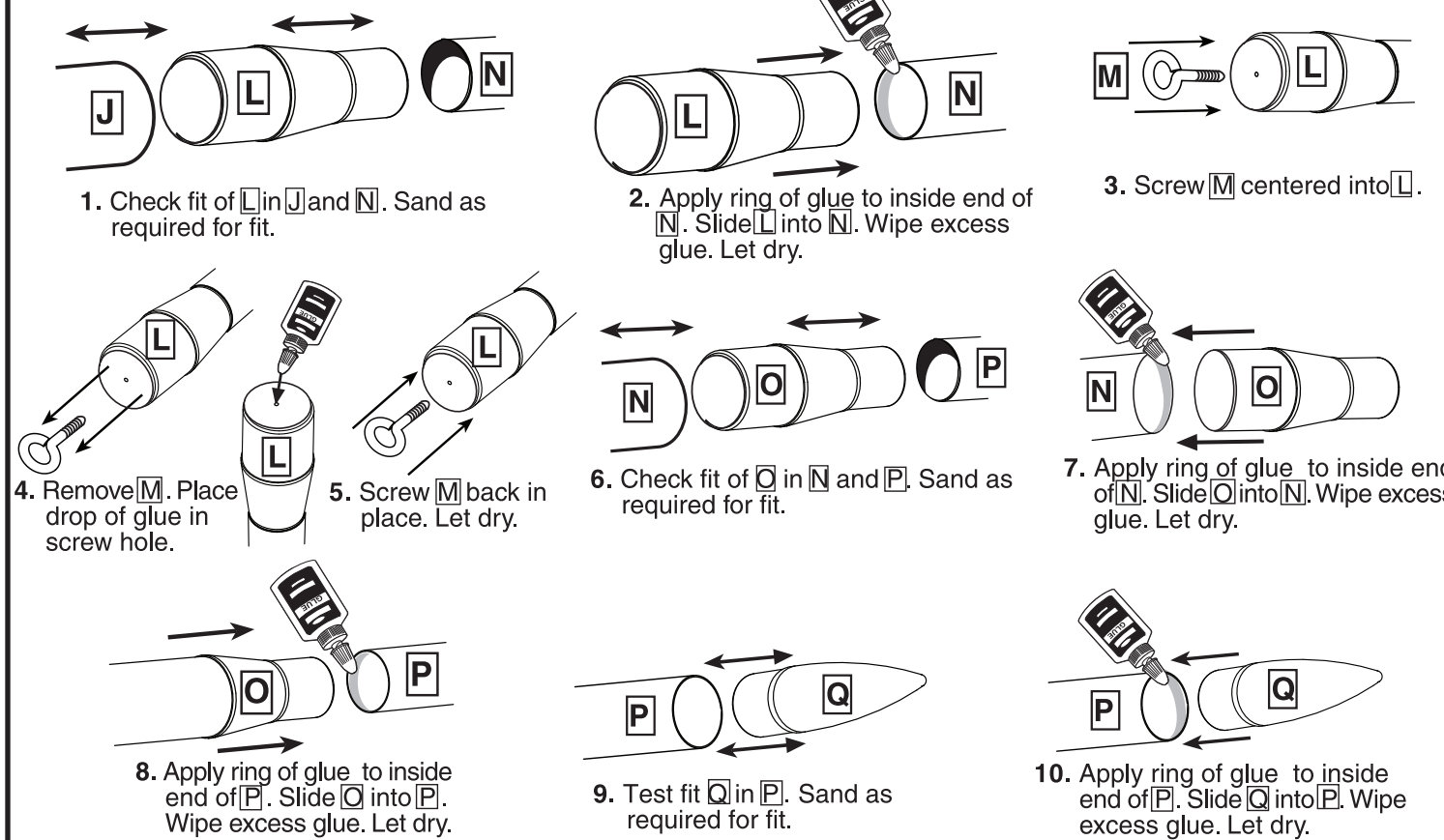

SHOCK CORD INSTALLATION

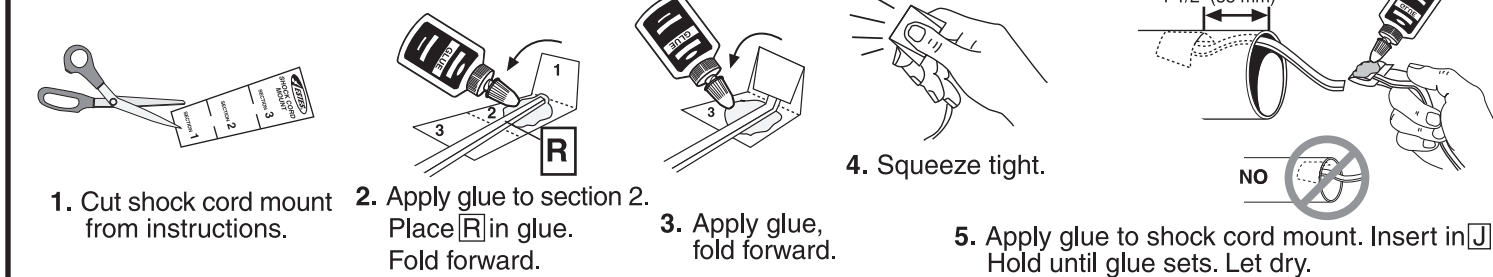

ROCKET FINISHING

NOTE: We have found Testors One Coat Lacquer, Testors Model Master spray paints and Testors Gloss Lacquer (#1961) to be excellent for providing a long lasting and durable finish on your rocket. Always be sure to spray your models outside or in a well ventilated area.

Steps for a Quality Finish:

1. Insert shock cord into body tube and hold in place with paper.
2. Lightly sand rocket with fine sandpaper (#320 or #400 grit).
3. Apply glue fillets to where fins and launch lug joints meet body tube.
 - a. Allow glue to dry overnight.
4. Use a stick inserted into the engine tube end of the rocket body for painting.
5. Hold the upper rocket section by the screw eye for painting.

