

## About Estes Industries, Inc.

In July 1958, G. Harry Stine of Model Missiles, Inc. in Denver, Colorado approached Vern Estes about making model rocket engines for them. On January 15, 1959, Vern's automated model rocket engine fabricating machine, "Mabel", produced the first of many millions of Estes model rocket engines. In 1960, Estes was producing more engines than Model Missiles could sell. Vern and his wife Gleda opened a mail order rocket company and introduced the Astron Scout and Astron Mark.

In 1961, a catalog was mimeographed and hand stitched on Gleda's sewing machine. Later that year, Estes Industries had outgrown the confined space in Denver. In December 1961, the entire operation was moved to an old farm in Penrose, Colorado quickly establishing the small town as the "Model Rocket Capital of the World."

Estes Industries was sold to Damon in September 1969. The name Estes is synonymous with model rocketry. Almost everyone remembers growing up firing Estes rockets or knowing someone that did. Estes Industries has introduced millions of youngsters of all ages to model rocketry for almost half a century.

## About the Starship Vega™

The original Starship Vega was designed by Wayne Kellner at Estes Industries. It was released as a futuristic planetary exploration vehicle in the style of illustrations by Frank Tinsley in the 1950's. The Starship Vega only had a production run of five years, but it is remembered fondly by thousands of modelers as their first futuristic model rocket kit. It was first offered in the 1979 Catalog as Catalog Number 1320 and retailed for \$6.50.

The Semroc Retro-Repro™ Starship Vega™ is very close in design to the original. Precision laser-cut fins and rings make the assembly easier. The addition of a Kevlar shock cord mount increases reliability. A large full-color waterslide decal sheet adds the finishing touches.

## What is a Retro-Repro?

A Retro-Repro™ is a retro reproduction of an out-of-production model rocket kit. It is a close approximation of a full scale model of an early historically significant model rocket kit from one of the many companies that pioneered the hobby over the past half century. A Retro-Repro™ is not a true clone or identical copy of the original. It incorporates improvements using modern technology, while keeping the flavor and build appeal of the early kits.

February 29, 2012

Copyright © 2012 Semroc Astronautics Corporation  
Box 1271 Knightdale, NC 27545 (919) 266-1977

**STARSHIP  
VEGA™**

**STARSHIP SERIES**

**CLASSIC DESIGN**

**EASY TO BUILD**

**BALSA FINS &  
NOSE CONE**

Design by  
Wayne Kellner

1979  
Retro-Repro

FLYING MODEL  
ROCKET KIT

LASER-CUT FINS

UNITED STATES

MADE IN THE USA

SEMROC

Made in the U.S.A by Semroc Astronautics Corporation - Knightdale, N.C. 27545

## Starship Vega™ Kit No. KV-78

Specifications	Engine	Approx. Altitude
Body Diameter 0.976" (2.5 cm)	A8-3	175'
Length 20.4" (51.8 cm)	B6-4	425'
Fin Span 9.0" (22.9 cm)	C6-5	900'
Net Weight 1.3 oz. (37.0 g)		

## PARACHUTE RECOVERY

# Parts List

# EXPLODED VIEW

- A 1 Balsa Nose Cone... BNC-50AR
- B 3 Balsa Nose Cones. BNC-5AW
- C 1 Body Tube..... BT-50L
- D 1 Body Tube..... BT-20J
- E 3 Body Tubes..... BT-5T
- F 1 Laser Cut Fins ..... FV-78
- G 1 Adapter Ring..... AR-2050
- H 1 Adapter Ring Split AR-2050S
- I 1 Mylar Ring ..... HR-20
- J 1 Engine Hook ..... EH-28
- K 3 Wood Dowels ..... WD-202
- L 2 Launch Lugs ..... LL-2AM
- M 1 Ring Set ..... CR-KV-78
- N 1 Elastic Cord..... EC-118
- O 1 Chute Pak..... CP-12RY
- P 1 Kevlar Thread ..... SCK-12
- Q 1 Screw Eye ..... SE-1
- R 1 Washer Weight..... WW-8
- S 1 Decal ..... DKV-78
- T 1 Wrap ..... IKV-78W

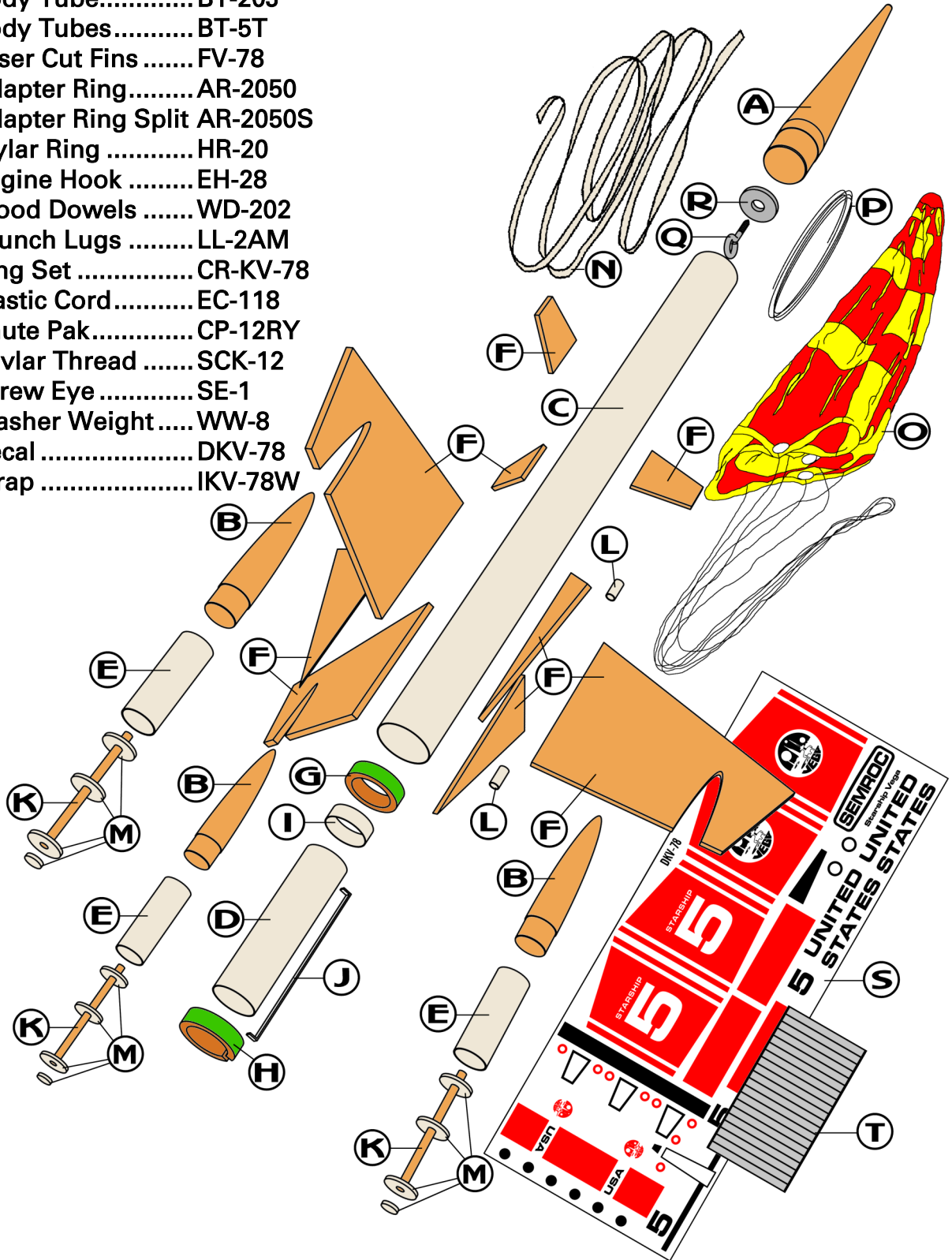

## BEFORE YOU START!

Make sure you have all the parts included in this kit that are listed in the Parts List in the center of these instructions. In addition to the parts included in this kit, you will also need the tools and materials listed below. Read the entire instructions before beginning to assemble your rocket. When you are thoroughly familiar with these instructions, begin construction. Read each step and study the accompanying drawings. Check off each step as it is completed. In each step, test-fit the parts together before applying any glue. It is sometimes necessary to sand lightly or build-up some parts to obtain a precision fit. If you are uncertain of the location of some parts, refer to the exploded view in the center of these instructions. It is important that you always ensure that you have adequate glue joints.

## TOOLS

In addition to the parts supplied, you will need the following tools to assemble and finish this kit.



## ASSEMBLY

1. These instructions are presented in a logical order to help you put your Starship Vega™ together quickly and efficiently. Check off each step as you complete it and we hope you enjoy putting this kit together.

## FIN PREPARATION

2. Lightly sand each side of both the laser-cut fin sheets (FV-78). Stack all like fins in sets. Line each set of fins up squarely and sand the fins back and forth over some fine sandpaper to get rid of the hold-in tabs as shown below.

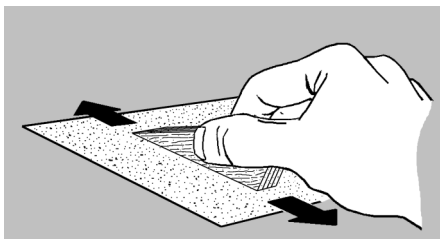

3. Round all the edges of each fin, except the root edges and the cutout for the nose cone in the large fins. The root edge will be glued to the body tube. Be careful with the tips of the large main fins until they are glued in a later step.

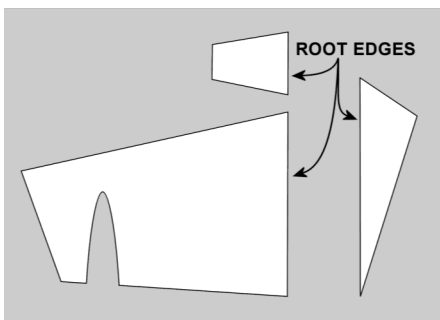

## ENGINE MOUNT

4. Bend the engine hook (EH-28) slightly so it forms a slight bow in the direction shown.

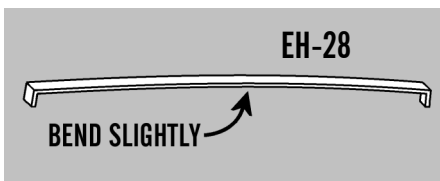

5. Place a mark 1/4" from one end of the engine tube (BT-20J).

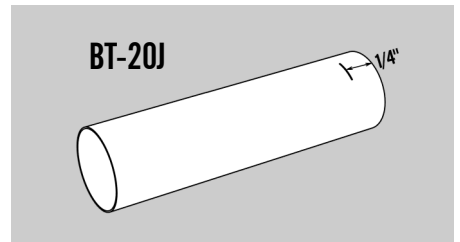

6. Using a hobby knife, punch a small slit at the marked line.

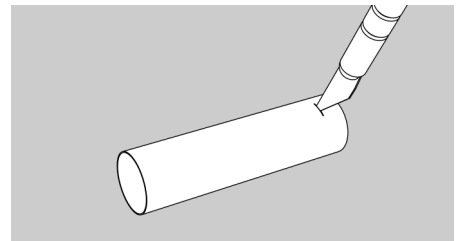

7. Tie a loop in one end of the yellow Kevlar® cord (SCK-12). Insert one end of the engine hook through the loop and into the punched slit.

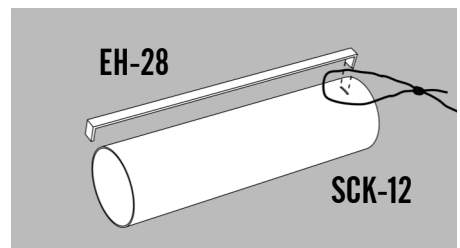

8. Slide the centering ring without the slot (AR-2050) from the bottom of the engine tube until it is close to the slit in the engine tube and the Kevlar cord. Apply a bead of glue around both sides of the joint formed by the ring and tube, keeping glue off the outside edge of the ring. Tuck the free end of the Kevlar cord into the engine tube to keep it out of the way.

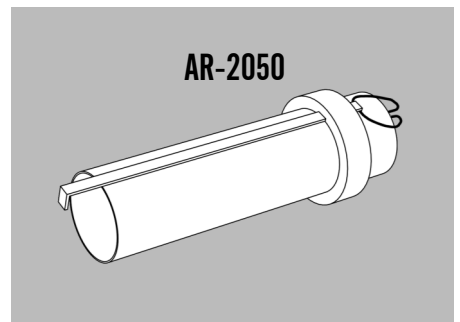

❑ 9. Slide the Mylar retaining ring (HR-20) over the end of the engine tube until it is centered on the tube. Apply a bead of glue around both sides of the joint formed by the ring and tube, keeping glue off the engine hook end closest to the bottom of the engine tube.

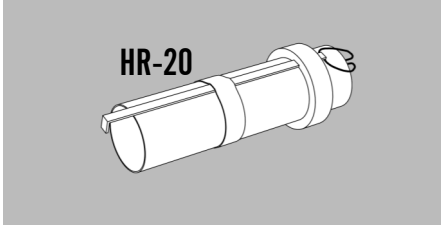

❑ 10. Slide the split centering ring (AR-2050S) over the end of the engine tube. Align the slot with the engine hook and the end of the ring just protruding from the end of the engine tube. Carefully apply a bead of glue around both sides of the ring at the joint it makes with the engine tube. Do not let any glue get on the engine hook.

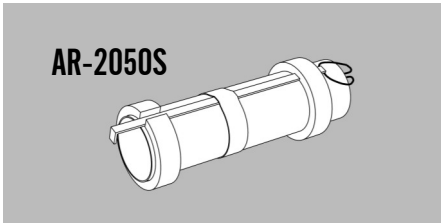

## PODS

❑ 11. Carefully punch out all the small rings from the laser-cut sheet. (CR-KV-78). Slide one of the punched rings over one of the dowels.(WD-202), centering it on the dowel. Apply a bead of glue on each side at the joint.

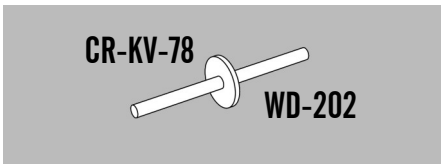

❑ 12. Apply a ring of glue around the hole in another of the small rings. Center one of the smaller discs over the ring. Try to keep any glue out of the hole. Make two more sets and allow all three sets to dry.

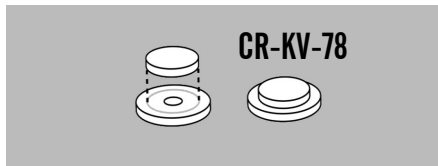

❑ 13. Complete one leg assembly by gluing one of the remaining rings to one end of the dowel assembly and one of the two-piece pads to the other. Make sure all three rings are perpendicular to the dowel. Allow to dry in a horizontal position, checking for runs. Repeat for the other two legs.

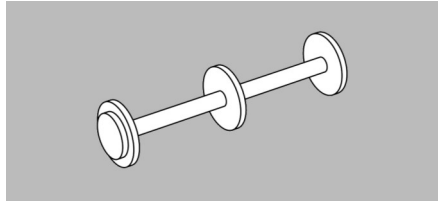

❑ 14. Apply a bead of glue inside one end of one of the small pod tubes (BT-5T). Insert one of the small nose cones (BNC-5AW) in the end of the tube. Allow to dry.

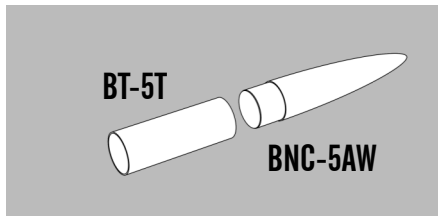

❑ 15. Apply a bead of glue inside the bottom of the pod tube. Insert one of the leg assemblies into the bottom of the tube until it is against the bottom of the nose cone.

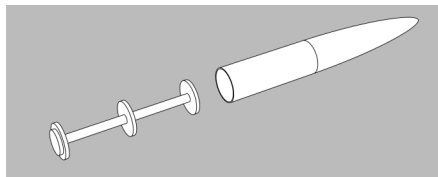

❑ 16. Apply a fillet of glue inside the bottom of the tube around the joint of the middle ring and the pod tube.

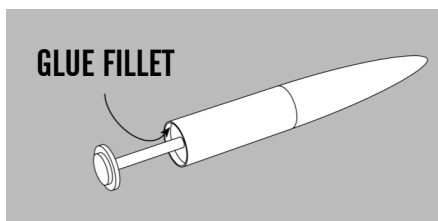

❑ 17. Apply a bead of glue around the nose cone cutout on one of the main fins. Insert the pod assembly into the cutout, centering the pod in the fin. Apply a fillet of glue around the joint formed by the nose cone and the fin on both sides. Allow to dry in an upright position, checking often to make sure the pod is centered in the fin. Repeat with the other two pod-fin assemblies.

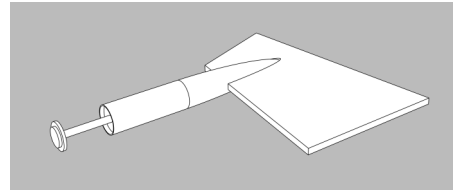

## MARK TUBE

❑ 18. Stand the large body tube (BT-50L) on the fin guide below and make the fin position marks on the sides of the tube. Find a convenient channel or groove such as a partially open drawer, a door jamb (as shown,) or a piece of molding. Using the channel, extend the marks the length of the tube to provide lines for aligning the fins.

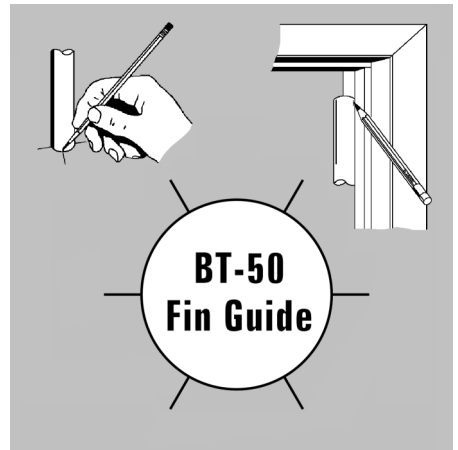

## ATTACH FINS

❑ 19. Apply glue to the root edge of one of the main fin-pod assemblies and position it along one of the lines drawn for the fins on the side of the body tube and 3/4" from the bottom of the main tube. Remove the fin, set it aside and allow it to almost dry, apply additional glue, and reposition.

Repeat for the other two assemblies using every other line. If you follow these instructions, the fins will not require much additional work to keep them aligned. Allow the assemblies to completely dry, checking carefully to make sure they are parallel with the main body tube.

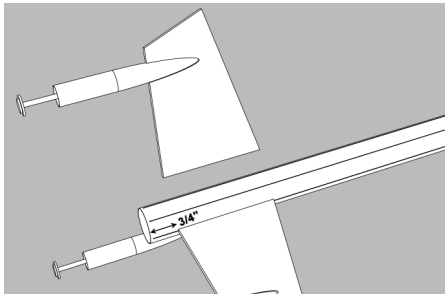

□ 20. Apply glue to the root edge of one of the triangular fins and position it along one of the lines drawn for the fins on the side of the body tube and even with the bottom of the main tube. Glue it using the same technique used on the main fins. Repeat for the other triangular fins. Allow the fins to completely dry, checking carefully to make sure they are parallel with the main body tube.

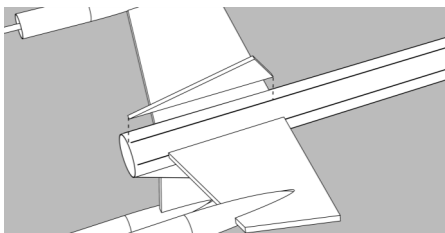

□ 21. Apply glue to the root edge of one of the small fins and position it along one of the lines drawn for the main fins on the side of the body tube and 4-5/8" from the top of the main tube. Glue it using the same technique used on the main fins. Repeat for the other small fins. Allow the fins to completely dry, checking carefully to make sure they are parallel with the main body tube.

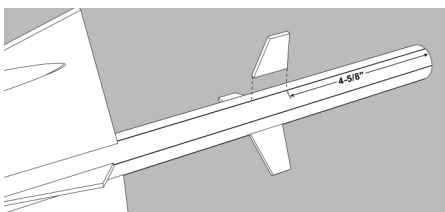

## LAUNCH LUG

□ 22. Apply a bead of glue to one of the launch lugs (LL-2AM) and apply it to the main body tube against one of the main fins and even with the bottom fin. Glue the other launch lug against one of the upper fins in line with the first launch lug and even with the bottom of the fin. Sight from one end to make sure they are aligned with each other.

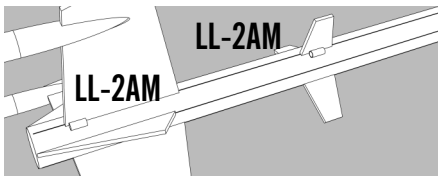

## ATTACH MOUNT

□ 23. Pull the Kevlar® cord out of the engine mount assembly. Tie the free end of the cord to one end of the elastic cord (EC-118) using an overhand knot. Store all the cord and shock cord back into the engine mount for now.

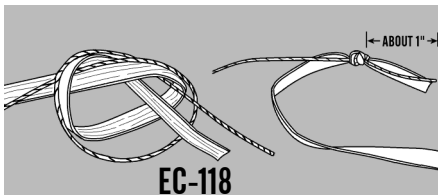

□ 24. Run a thick bead of glue inside the main tube and push the engine mount into the main tube until the bottom of the engine tube is even with the bottom of the main tube.

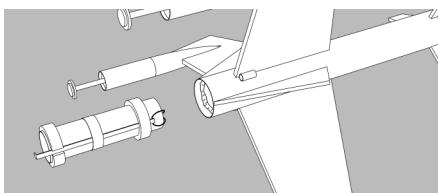

## APPLY FILLETS

□ 25. After the fin assembly is completely dry, run a small bead of glue along both sides of each of the fin-body tube joints. Using your forefinger, smooth the glue into fillets. Allow this assembly to dry in a vertical position.

## NOSE CONE

□ 26. Insert the nose cone (BNC-50AR) in the main tube and check for proper fit. The nose cone should be snug to hold itself in alignment. If it is too loose, masking tape may be needed. If it is too tight, sand the shoulder slightly.

□ 27. Insert the screw eye (SE-1) into the center of the nose block, remove, and insert glue into the hole. Reinsert the screw eye through the washer weight (WW-8) into the nose cone. Allow to dry.

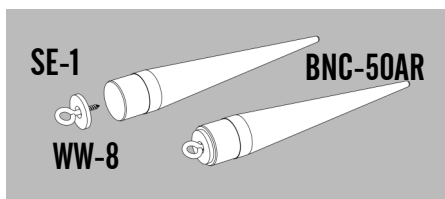

## FINAL ASSEMBLY

□ 28. Assemble the chute (CP-12) using instructions printed on the canopy. Pull the lines tight on the chute and make sure they are all of equal length. Attach the chute by tying them to the screw eye. Put a drop of glue on the joint to keep the lines from moving. Attach the free end of the elastic cord to the screw eye. Put a drop of glue on that joint as well.

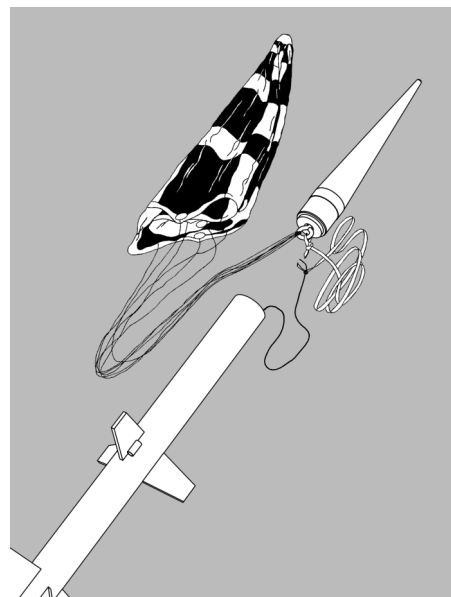

## FINISHING

❑ **29.** When the fillets have dried, prepare balsa surfaces for a smooth professional looking finish. Fill the wood grain with balsa fillercoat or sanding sealer. When dry, sand with fine sandpaper. Repeat until smooth.



1st coat of fillercoat



2nd coat of fillercoat



After 1st sanding



3rd coat of fillercoat



After 1st sanding

❑ **30.** After all balsa surfaces have been prepared, wipe off all balsa dust with a dry cloth. First spray the model with an enamel primer. Choose high visibility colors like white for the final color.

❑ **31.** Spray painting your model with a fast-drying enamel will produce the best results. PATIENCE...is the most important ingredient. Use several thin coats, allowing each coat to completely dry before the next coat. Start each spray a few inches above the model and end a few inches below the model. Keep the can about 12" away and use quick light coats. The final coat can be a little heavier to give the model a glossy wet-looking finish.

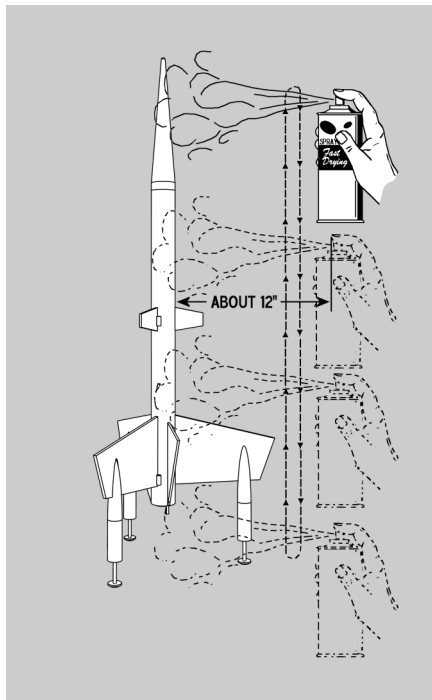

❑ **32.** After the paint has dried, decals should be applied. The decals supplied with the Starship Vega™ are waterslide decals. Each decal should be cut separately from the sheet. Think about where you want to apply each decal and check for fit before wetting the decal. Use the cover photo for suggested placement. Dip each decal in a small dish of water that has a drop of detergent. It will take about 30 seconds before the decal is loose enough to apply. The body wrap uses a self-adhesive backing. Cut it close to the outside black line and apply it carefully.

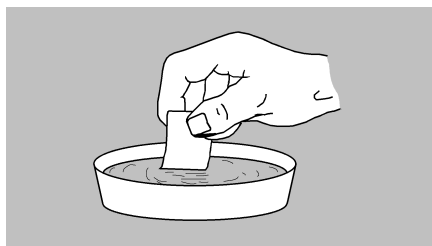

❑ **33.** Slide the decal in place and use the paper backing to work the bubbles out. Repeat for all the decals.

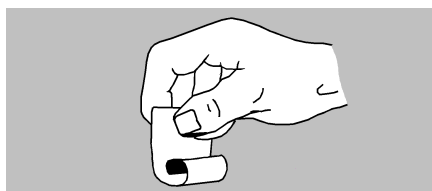

## FLIGHT PREPPING

❑ **34.** Mounting the engine: Insert the engine and make sure the engine hook keeps the engine in snugly. The hook may be slightly bent to make sure the engine is retained.

❑ **35.** Apply a few sheets of recovery wadding in the top of the main body tube. Fold the parachute and pack it and the shock cord on top of the recovery wadding. Slide the nose cone into place, making sure it does not pinch the shock cord or parachute.

❑ **36.** Refer to the model rocket engine manufacturer's instructions to complete the engine prepping. Different engines have different igniters and methods of hooking them up to the launch controllers.

❑ **37.** Carefully check all parts of your rocket before each flight as a part of your pre-flight checklist. Launch the Starship Vega™ from a 1/8" diameter by 36" long launch rod.

❑ **38.** After each flight, promptly remove the spent engine casing and dispose of properly.